



Forschungsschwerpunkt

Algorithmen und mathematische Modellierung



The number of maximum matchings in a tree

Clemens Heuberger and Stephan G. Wagner

Project Area(s):

Analysis of Digital Expansions with Applications in Cryptography

Institut für Optimierung und Diskrete Mathematik (Math B)

THE NUMBER OF MAXIMUM MATCHINGS IN A TREE

CLEMENS HEUBERGER AND STEPHAN WAGNER

ABSTRACT. We determine upper and lower bounds for the number of maximum matchings (i.e., matchings of maximum cardinality) $m(T)$ of a tree T of given order. While the trees that attain the lower bound are easily characterised, the trees with largest number of maximum matchings show a very subtle structure. We give a complete characterisation of these trees and derive that the number of maximum matchings in a tree of order n is at most $O(1.391664^n)$ (the precise constant being an algebraic number of degree 14). As a corollary, we improve on a recent result by Górska and Skupień on the number of maximal matchings (maximal with respect to set inclusion).

1. INTRODUCTION AND STATEMENT OF MAIN RESULTS

Many problems in graph theory can be described as follows: for a certain class of graphs and a graph parameter, determine the largest and smallest possible value of the parameter, given the order of a graph (and possibly other conditions). One family that is particularly well-studied in this regard is the family of trees, not only because of their simplicity, but also in view of their many applications in various areas of science.

On the other hand, lots of natural graph parameters are defined as the number of vertex or edge subsets of a certain kind; we mention, for example, the number of independent vertex subsets [15, 18], the number of matchings [7], the number of dominating or efficient dominating sets [2, 3] or the number of subtrees [13, 21]. Some of them play an important role in applications as well, for instance the number of matchings that is known as *Hosoya index* in mathematical chemistry [9, 12] and is also connected to the *monomer-dimer model* of statistical physics [10]. The same can be said of the number of independent sets, which is studied under the name *Merrifield-Simmons index* in chemistry [17] and which is related to Hard Models in physics [1]. For both these parameters, the minimum and maximum among all trees of given order are well known and are obtained for the star and the path respectively. A tremendous number of publications deals with related problems, concerning restricted classes of trees or tree-like graphs; the interested reader is referred to [22] and the references therein.

It is natural to consider variants of these graph parameters: instead of the number of matchings, one might be interested in the number of maximal matchings (maximal with respect to inclusion) or maximum matchings (matchings of largest possible cardinality). The same holds, of course, for the number of independent sets.

The number of maximal independent sets is treated in [19, 23]—the maximum turns out to occur for an extended star. More recently, maximal matchings were studied by Górska and Skupień [5], who determined exponential upper and lower bounds for the maximum number of maximal matchings among all trees of given order. To the best of our knowledge, however, there are no analogous results on the number of maximum matchings, i.e., matchings of largest possible cardinality. Clearly, any maximum (cardinality) matching is also maximal with respect to inclusion,

Date: November 30, 2010.

2010 Mathematics Subject Classification. 05C70; 05C05; 05C35.

Key words and phrases. maximum matchings, trees, bounds, structural characterisation.

C. Heuberger is supported by the Austrian Science Foundation FWF, project S9606, that is part of the Austrian National Research Network “Analytic Combinatorics and Probabilistic Number Theory.” This paper was partly written while C. Heuberger was a visitor at Stellenbosch University.

This material is based upon work supported financially by the National Research Foundation of South Africa under grant number 70560.

but the converse is not true. In fact, graphs for which every maximal matching is also a maximum matching are known as *equimatchable* [16].

In the following, we denote the number of maximum matchings in a graph G by $m(G)$. Our goal is to characterise the trees of given order n for which the maximum and the minimum of this parameter are attained. This problem also has an algebraic interpretation: it is well known that the characteristic polynomial of a tree T of order $|T| = n$ coincides with the *matching polynomial* [16]

$$\phi(T, x) = \sum_{k=0}^{\lfloor n/2 \rfloor} (-1)^k a_k(T) x^{n-2k},$$

where $a_k(T)$ is the number of matchings of cardinality k in T . This is a special case of a general theorem on the coefficients of the characteristic polynomial—see for instance [4]. It follows that $m(T)$ is precisely the (absolute value of the) last nonzero coefficient of $\phi(T, x)$ and thus the product of the absolute values of all nonzero eigenvalues. In this sense, $m(T)$ is a multiplicative analogue of the so-called *energy* of a graph [8, 9], which is defined as the sum of the absolute values of all eigenvalues.

The lower bound for $m(T)$ is almost trivial, and the trees that attain it can also be characterised easily:

Theorem 1.1. *For any tree T of even order n , $m(T) \geq 1$ with equality if and only if T has a perfect matching. For a tree T of odd order $n > 1$, $m(T) \geq 2$ with equality if and only if T is obtained from a tree T' of order $n - 1$ with a perfect matching by doubling one of the leaves (i.e., choosing a leaf v and attaching a second leaf to v 's unique neighbour).*

We note that a path of even order is an example of a tree of even order admitting a perfect matching.

The analogous problem asking for the largest possible number of maximum matchings appears to be much harder. The bound provided by Górska and Skupień for the number of maximal matchings immediately provides an upper bound for the number of maximum matchings, so that we have $m(T) = O(1.395337^n)$ (the constant being a root of the algebraic equation $x^4 - 2x - 1$) by the result stated in [5]. We improve this to the following:

Theorem 1.2. *For $n \neq \{6, 34\}$, there is a unique tree T_n^* of order n that maximises $m(T)$. For $n = 6$ and $n = 34$, there are two such trees. Asymptotically,*

$$m(T_n^*) \sim c_{n \bmod 7} \lambda^{n/7},$$

where $\lambda = \frac{1}{2}(11 + \sqrt{85}) \approx 10.1097722286464$ is the larger root of the polynomial $x^2 - 11x + 9$ and the constants c_j , $j \in \{0, \dots, 6\}$, are given in Table 1.

While the improvement in the constant (from 1.395337 to $\lambda^{1/7} \approx 1.391664$) seems modest, the main part of the theorem is the characterisation of the trees T_n^* , which will be stated explicitly in Section 3. Figure 1 shows T_{181}^* as an example. Since maximum matchings are automatically maximal matchings, the theorem also improves on the lower bound for the maximum number of maximal matchings that was given by Górska and Skupień in [5], which is $\Omega(1.390972^n)$ (the precise constant being $\sqrt[14]{51 + 5\sqrt{102}}$).

The paper is organised as follows: in the following section, we deal with the simple lower bound (Theorem 1.1), the rest is devoted to the proof of Theorem 1.2. The structure of the “optimal” trees T_n^* is described explicitly in Section 3, making use of the concept of an *outline graph*. Then, some important preliminary results (Section 4) and information about the local structure (Section 5) are gathered. The global structure is discussed in Section 6. The proof is rather long and technical—one of the reasons we consider this inevitable is the fact that seven different cases occur in the structure of the optimal trees, and that there is also a number of exceptions from the general pattern (note the case $n = 34$ in Theorem 1.2: the precise characterisation of the structure is only valid for $n \geq 35$). Another reason is that there are many trees that almost reach the upper bound, as can be seen from some of the estimates made on the way to our main result.

j	c_j	
0	$\frac{67\lambda - 71}{765}$	$\approx 0.792620574273610$
1	$\frac{11\lambda - 18}{85\lambda^{1/7}}$	$\approx 0.787947762616490$
2	$\frac{101047\lambda - 90171}{614125\lambda^{2/7}}$	$\approx 0.783080426542439$
3	$\frac{4996\lambda - 4448}{21675\lambda^{3/7}}$	$\approx 0.788434032505851$
4	$\frac{27\lambda - 21}{85\lambda^{4/7}}$	$\approx 0.790280714748050$
5	$\frac{3209\lambda - 2817}{7225\lambda^{5/7}}$	$\approx 0.785510324593434$
6	$\frac{6451616\lambda - 5743408}{10440125\lambda^{6/7}}$	$\approx 0.784269603628599$

TABLE 1. Constants c_j in the asymptotics of $m(T_n^*)$.

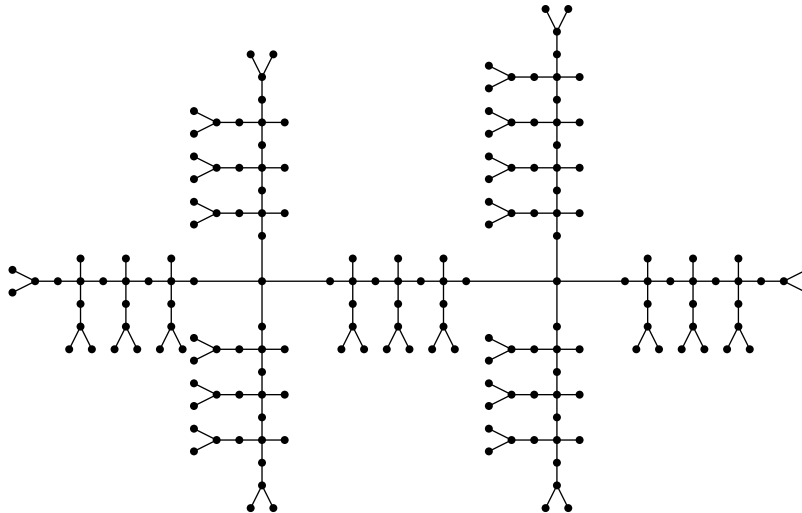

FIGURE 1. Unique optimal tree of order 181.

2. THE LOWER BOUND

Let us start with the simple lower bound; as stated in Theorem 1.1, the minimum of $m(T)$ is either 1 or 2, depending on the parity of the order:

Proof. In the case of even n , the inequality is trivial, so that we only have to determine the cases of equality. If T has a perfect matching, then this perfect matching can be reconstructed uniquely, starting from the leaves. Hence equality holds in this case. Otherwise, consider a tree T of order n and a maximum matching M . Since it is not a perfect matching, there is a vertex v that is not covered by the matching. Now choose an arbitrary neighbour w of v . Then w must be covered by the matching M , since one could otherwise add the edge vw to M to obtain a larger matching, contradicting the choice of M . Now replace the edge that covers w by the edge vw to obtain a second matching of the same cardinality as M , which shows that $m(T) \geq 2$ unless T has a perfect matching.

Now let us determine which trees of odd order satisfy $m(T) = 2$. Consider once again a maximum matching. Since the above argument can be carried out for any vertex that is not

covered by M , we can only have $m(T) = 2$ if there is exactly one vertex v that is not covered. Furthermore, v must be a leaf: otherwise, we could apply the exchange procedure for each of its neighbours to obtain at least 3 distinct maximum matchings. Let w be v 's unique neighbour and assume that w is covered by an edge $v'w$ in M . Then v' must also be a leaf, since we could otherwise replace $v'w$ by vw and repeat the argument. This shows that equality can only hold in the described case. \square

As we will see in the following sections, the analogous question for the maximum of $m(T)$ is much harder and requires a completely different approach. Let us first give a precise description of the trees T_n^* in Theorem 1.2.

3. THE UPPER BOUND: DESCRIPTION OF THE OPTIMAL TREES

As mentioned in the introduction, we define $m(T)$ to be the number of matchings of maximal cardinality of a tree T . A tree T is called an *optimal tree* if it maximises $m(T)$ over all trees of the same order.

The results on the global structure are formulated in terms of *leaves*, *forks*, and *chains*.

- Definition 3.1.** (1) The graph of order 1 is also denoted by L (leaf).
(2) The rooted tree in Figure 2(a) (with root r) is denoted by F (fork).
(3) Chains are defined recursively: for a rooted tree (T, r) , we define the rooted tree (CT, s) as in Figure 2(b). For $k \geq 1$ and a rooted tree T , we set

$$C^k T := C(C^{k-1} T) \text{ and } C^0 T = T.$$



FIGURE 2. Fork and chain (Definition 3.1)

Using these definitions, we can see five copies of $C^3 F$ and one copy of $C^4 F$ as rooted subtrees of the optimal tree in Figure 1.

Formulating as much as possible using the notations L , F and C^k turns out to give compact representations for optimal trees. Let us formalise this concept:

Definition 3.2. Let T be a tree. We construct the *outline graph* of T as follows: first, all occurrences $C^k F$ and $C^\ell L$ as rooted subtrees of T are replaced by special leaves “ $C^k F$ ” and “ $C^\ell L$ ”, respectively (where replacement takes place by decreasing order of the replaced rooted subtree). In a second step, we consider all occurrences of subtrees $C^k T'$ where T' has a unique branch T'' . Every such subtree is replaced by the subtree T'' , linked to the rest by a special edge “ C_*^k ”.

As an example, the outline graph of the tree from Figure 1 is shown in Figure 3.

We are now able to state our main theorem fully describing optimal trees.

Theorem 3.3. *Let $n \geq 4$ and $n \notin \{6, 10, 13, 20, 34\}$. Then there is a unique optimal tree T_n^* of order n .*

- (1) If $n \equiv 1 \pmod{7}$, then $T_n^* = C^{(n-1)/7} L$.
(2) If $n \equiv 2 \pmod{7}$, then T_n^* is shown in Figure 4(a), where

$$k_0 = \max \left\{ 0, \left\lfloor \frac{n-37}{35} \right\rfloor \right\}, \quad k_j = \begin{cases} \left\lfloor \frac{n-2+7j}{35} \right\rfloor & \text{if } n \geq 37, \\ \left\lfloor \frac{n-9+7j}{35} \right\rfloor & \text{if } n \leq 30 \end{cases}$$

for $j \in \{1, 2, 3, 4\}$.

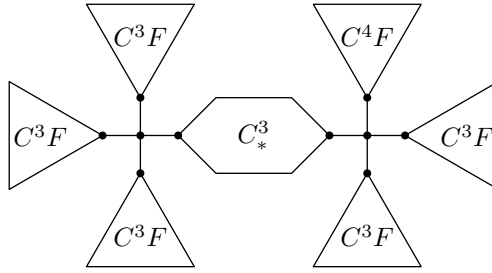

FIGURE 3. Outline of the unique optimal tree of order 181.

- (3) If $n \equiv 3 \pmod{7}$, then T_n^* is shown in Figure 4(b), where

$$k_j = \left\lfloor \frac{n - 17 + 7j}{28} \right\rfloor$$

for $j \in \{0, 1, 2, 3\}$.

- (4) If $n \equiv 4 \pmod{7}$, then $T_n^* = C^{(n-4)/7}F$.
 (5) If $n \equiv 5 \pmod{7}$, then T_n^* is shown in Figure 4(c), where

$$k_j = \left\lfloor \frac{n - 5 + 7j}{21} \right\rfloor$$

for $j \in \{0, 1, 2\}$.

- (6) If $n \equiv 6 \pmod{7}$, then T_n^* is shown in Figure 4(d), where

$$k_j = \left\lfloor \frac{n - 27 + 7j}{49} \right\rfloor$$

for $0 \leq j \leq 6$.

- (7) If $n \equiv 0 \pmod{7}$, then T_n^* is shown in Figure 4(e), where

$$k = \frac{n - 7}{7}.$$

If $n \in \{1, 2, 3, 10, 13, 20\}$, there is also a unique optimal tree T_n^* of order n . For $n \in \{1, 2, 3\}$, there is only one tree of order n . For $n \in \{10, 13, 20\}$, T_n^* is shown in Figure 5.

For $n \in \{6, 34\}$, there are two non-isomorphic optimal trees $T_{n,1}^*$ and $T_{n,2}^*$ of order n . For $n = 6$, $T_{6,1}^*$ (the star of order 6) and $T_{6,2}^*$ are shown in Figure 5.

For $n = 34$, both $T_{34,1}^*$ and $T_{34,2}^*$ have the shape as in Figure 4(d). We have $(k_0, k_1, k_2, k_3, k_4, k_5, k_6) = (0, 0, 0, 0, 0, 0, 1)$ for $T_{34,1}^*$ (this corresponds to the general case $n \equiv 6 \pmod{7}$ as described above) and $(k_0, k_1, k_2, k_3, k_4, k_5, k_6) = (1, 0, 0, 0, 0, 0, 0)$ for $T_{34,2}^*$.

Remark 3.4. The quasi-periodicity of length 7 is somewhat reminiscent of the situation encountered for dominating sets [2, 3], even though there are certain differences.

4. THE UPPER BOUND: PRELIMINARIES

4.1. The bipartition condition. A tree may always be seen as a bipartite graph. In the case of an optimal tree, however, the bipartition of the vertices corresponds to a specific behaviour in terms of maximum matchings, as will be shown in this section. This will also allow us to somewhat decompose the problem.

We start with a few definitions.

Definition 4.1. Let T be a forest. The *matching number* $\mu(T)$ is the maximum cardinality of a matching of T . Hence a matching of T is a maximum matching if it has cardinality $\mu(T)$. Denoting the empty graph by \emptyset , it is convenient to set $\mu(\emptyset) = 0$ and $m(\emptyset) = 1$.

Definition 4.2. A forest T is called an *optimal forest* if it maximises $m(T)$ over all forests of the same order.

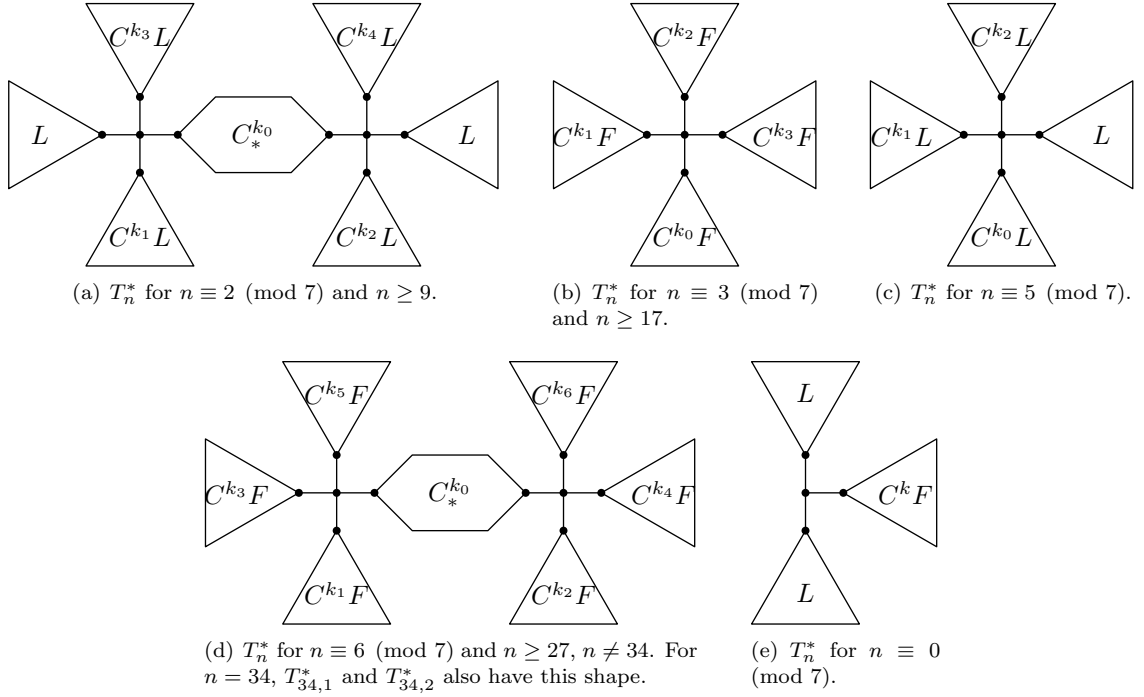
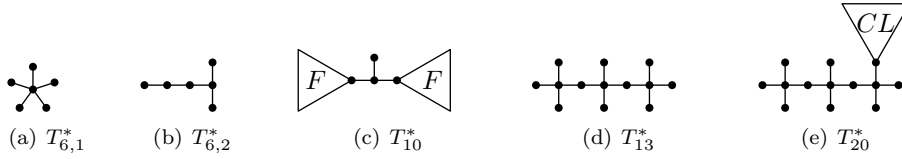

FIGURE 4. Optimal trees.

FIGURE 5. Optimal trees for $n \in \{6, 10, 13, 20\}$.

We now define the type of a vertex. These types will later be seen to correspond to the bipartition of the set of vertices of optimal trees.

Definition 4.3. Let T be a forest. A vertex v is said to be of type A if T admits a maximum matching that does not cover v . Otherwise, v is said to be of type B .

A first step towards the main result on the bipartition holds for all trees: there are no edges between vertices of type A :

Lemma 4.4. Let T be a tree, $s \in V(T)$ of type A , and t a neighbour of s in T . Then t is of type B . Denoting the connected components of $T - st$ by T_s and T_t with $s \in T_s$ and $t \in T_t$, cf. Figure 6, we have

$$\begin{aligned} \mu(T_s - s) &= \mu(T_s), & \mu(T_t - t) &= \mu(T_t) - 1, \\ \mu(T) &= \mu(T_s) + \mu(T_t), & m(T) &= m(T_s)m(T_t) + m(T_s - s)m(T_t - t). \end{aligned}$$

Proof. We first note that

$$\mu(T - v) \leq \mu(T) \leq \mu(T - v) + 1$$

holds for any vertex v of any tree T , as any maximum matching of $T - v$ is a matching of T and any maximum matching of T minus possibly the edge covering v is a matching of $T - v$.

Any maximum matching M of the tree T either contains the edge st or it does not contain the edge st . In the first case, M decomposes into a maximum matching of $T_s - s$, a maximum

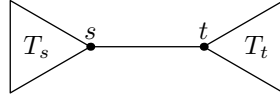
FIGURE 6. Decomposition of T for Lemma 4.4 and Proposition 4.7.

matching of $T_t - t$ and the edge st , which implies that $\mu(T) = \mu(T_s - s) + \mu(T_t - t) + 1$. In the second case, M decomposes into a maximum matching of T_s and a maximum matching of T_t , which implies that $\mu(T) = \mu(T_s) + \mu(T_t)$. We conclude that

$$\mu(T) = \max\{\mu(T_s - s) + \mu(T_t - t) + 1, \mu(T_s) + \mu(T_t)\}. \quad (4.1)$$

As s is of type A , there is a maximum matching M of T not covering s , hence we have $\mu(T) = \mu(T_s - s) + \mu(T_t)$. In view of (4.1), this implies that $\mu(T_t) \geq \mu(T_t - t) + 1$, i.e., $\mu(T_t - t) = \mu(T_t) - 1$, and $\mu(T_s - s) \geq \mu(T_s)$, i.e., $\mu(T_s - s) = \mu(T_s)$.

In this case, we also have $\mu(T - t) = \mu(T_t - t) + \mu(T_s) < \mu(T_t) + \mu(T_s) = \mu(T)$, i.e., t is of type B . Finally, $m(T_s)m(T_t)$ counts the number of maximum matchings of T not containing st and $m(T_s - s)m(T_t - t)$ counts the number of maximum matchings of T containing st , their sum is therefore $m(T)$. \square

We now show that in almost all cases, optimal forests are trees, so we may restrict our attention to trees afterwards. Nevertheless, at one point, we will also use this result as a technical tool when considering trees.

Lemma 4.5. *Let T be an optimal forest of order at least 3. Then T is connected, i.e., T is a tree.*

Proof. Let T_1 and T_2 be connected components of T . For simplicity, we may assume that these are the only connected components of T ; otherwise, we use the following argument inductively.

As T is optimal, each of its connected components has to be optimal.

If both T_1 and T_2 are of order 1, then they both only admit the empty matching, inserting an edge between these two vertices does not alter the number of maximum cardinality matchings.

Next, we note that for $n \geq 3$, the star S_n on n vertices satisfies $m(S_n) = n - 1 > 1$. Thus an optimal forest of order at least 3 does not admit a perfect matching, as perfect matchings of trees are unique (see Theorem 1.1). This implies that an optimal forest of order at least 3 has a vertex of type A . As the unique vertex of a tree of order 1 is also of type A , we conclude that all optimal trees except the tree of order 2 have a vertex of type A .

As any neighbour of any vertex of type A is of type B by Lemma 4.4 and the vertices of the tree of order 2 also are of type B , we conclude that every optimal tree of order at least 2 has a vertex of type B .

If T_1 and T_2 are both of order 2, then there is no vertex of type A , thus T is not optimal.

So we may now assume that $v \in T_1$ is of type A and $w \in T_2$ is of type B . If we insert the edge vw , we obtain a new graph $T' = T + vw$. As in Lemma 4.4, we obtain

$$\mu(T') = \max\{\mu(T_1 - v) + \mu(T_2 - w) + 1, \mu(T_1) + \mu(T_2)\}.$$

As v is of type A (with respect to T_1) and w is of type B (with respect to T_2), we have $\mu(T_1 - v) = \mu(T_1)$ and $\mu(T_2 - w) + 1 = \mu(T_2)$. This implies that $\mu(T') = \mu(T_1 - v) + \mu(T_2)$, i.e., v is of type A with respect to T' and Lemma 4.4 can be applied to yield

$$m(T') = m(T_1)m(T_2) + m(T_1 - v)m(T_2 - w) > m(T_1)m(T_2) = m(T),$$

contradiction.

Thus the only disconnected optimal forest is the forest consisting of exactly two isolated vertices. \square

We can now formalise what we will call the bipartition condition.

Definition 4.6. Let T be a tree. We say that T fulfils the *bipartition condition* if the two classes in T 's unique bipartition contain precisely the vertices of type A and B respectively.

It turns out that indeed almost all optimal trees satisfy this condition.

Proposition 4.7. *Let T be an optimal tree of order at least 3. Then T fulfils the bipartition condition.*

Let st be an edge of T where s is of type A and t is of type B . The connected components of $T - st$ are denoted by T_s and T_t with $s \in T_s$ and $t \in T_t$. Then s and t are of types A and B with respect to the trees T_s and T_t , respectively. Furthermore,

$$m(T) = m(T_s)m(T_t) + m(T_s - s)m(T_t - t). \quad (4.2)$$

Proof. Assume that s and t are two adjacent vertices of type B .

If we have $\mu(T_s - s) + \mu(T_t - t) + 1 = \mu(T_s) + \mu(T_t)$, then (w.l.o.g.) $\mu(T_s - s) = \mu(T_s)$ and $\mu(T_t - t) = \mu(T_t) - 1$. In this case, we obtain $\mu(T) = \mu(T_s - s) + \mu(T_t)$, i.e., s is of type A . Contradiction.

Next, we consider the case that $\mu(T_s - s) + \mu(T_t - t) + 1 < \mu(T_s) + \mu(T_t) = \mu(T)$, i.e., the case that st is not contained in any maximum matching of T . Deleting the edge st resulting in a forest $T' = T - st$ does not alter the number of maximum matchings, i.e., $m(T) = m(T')$. By Lemma 4.5, T' and therefore T are not optimal, contradiction.

Finally, we consider the case $\mu(T_s - s) + \mu(T_t - t) + 1 > \mu(T_s) + \mu(T_t) = \mu(T)$, i.e., the case that st is contained in every maximum matching of T . Deleting all edges incident to s or t leads to a disconnected forest of the same order and the same number of maximum matchings. Contradiction.

Thus exactly one of s and t , say s , is of type A by Lemma 4.4 and the remaining assertions of this proposition are restatements of the results of Lemma 4.4. \square

4.2. Rooted Trees. For many of our arguments, we will designate a vertex of a tree as the root and recursively consider subtrees. To this end, we collect a few definitions as well as some recursive formulæ for the number of maximum matchings.

We assume that all rooted trees are non-empty. A rooted tree with underlying tree T and root r will be denoted by the pair (T, r) ; frequently, we will simply write T if the root is clear from the context. An important operation that we will frequently apply is to choose another vertex $s \in V(T)$ as the new root. We will usually denote the resulting rooted tree by a new symbol (T', s) (and thus abbreviated to T') although the underlying unrooted trees T and T' are identical.

As usual, the branches of a rooted tree (T, r) of the shape as Figure 7 are the rooted trees $(T_1, r_1), \dots, (T_k, r_k)$.

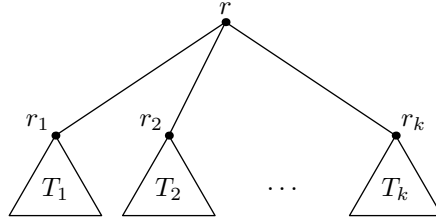

FIGURE 7. Rooted tree with branches.

A *rooted subtree* (T', v) of an unrooted tree T is a connected component of $T - vw$ for some edge vw of T such that $v \in T'$. Note that this definition forces T' to be a proper subtree of T .

A rooted subtree (T', v) of a rooted tree (T, r) is the connected component of $T - vw$ containing v , where w has to be the parent of v , i.e., T' is the subgraph induced by all the successors of v . We will also write $T' = T(v)$ in this case.

Let T be a tree and v be a vertex of T with neighbours r_1, \dots, r_k . The connected components of $T - v$ are denoted by T_1, \dots, T_k such that $r_j \in T_j$ for all j . Then the rooted trees $(T_1, r_1), \dots, (T_k, r_k)$ are said to be the *rooted connected components of $T - v$* (and usually, the roots r_j will not be mentioned).

Definition 4.8. Let (T, r) be a rooted tree.

- (1) We define $m_1(T)$ to be the number of maximum matchings of T covering the root r .
- (2) We define $m_0(T)$ to be $m(T-r)$, the number of maximum matchings of $T-r$.
- (3) The *type* of T is defined to be the type of the root as a vertex of the unrooted tree, i.e., (T, r) is of type A if $\mu(T-r) = \mu(T)$ and of type B if $\mu(T-r) = \mu(T) - 1$. We sometimes write $\text{type}(T) = A$ and $\text{type}(T) = B$, respectively.

Thus (T, r) is of type A if and only if it admits a maximum matching not covering the root r . We have

$$\mu(L) = 0, \quad m(L) = 1, \quad m_0(L) = 1, \quad m_1(L) = 0 \quad (4.3)$$

for the rooted tree L of order 1, which implies that it is a rooted tree of type A .

Definition 4.9. We define the *bipartition condition for rooted trees* recursively as follows: a rooted tree of order 1 (rooted at its only vertex) is said to satisfy the bipartition condition. If (T, r) is a rooted tree with branches $(T_1, r_1), \dots, (T_k, r_k)$, then the rooted tree (T, r) is said to fulfil the bipartition condition if all branches (T_j, r_j) fulfil the bipartition condition and the type of (T, r) is not equal to the type of any of the branches (T_j, r_j) .

Remark 4.10. Let T be an optimal tree of order at least 3 and (S, r) be a rooted subtree of T . Then the type of r as vertex of T coincides with the type of S and S fulfils the bipartition condition for rooted trees by Proposition 4.7.

The main goal behind the definition of the two different types is to provide a recursive method to compute $m(T)$. Note first that for a rooted tree (T, r) , we have

$$m(T) = \begin{cases} m_0(T) + m_1(T), & \text{if } (T, r) \text{ is of type } A, \\ m_1(T), & \text{if } (T, r) \text{ is of type } B. \end{cases}$$

We now give recursive formulæ for these quantities in terms of the branches of a rooted tree. Here, for technical reasons, we do not assume the bipartition condition for rooted trees, but a weaker version only, and derive the bipartition condition for rooted trees.

Lemma 4.11. *Let (T, r) be a rooted tree and $(T_1, r_1), \dots, (T_k, r_k)$ its branches. We assume that T_1, \dots, T_k are of the same type. Then T is of the other type and we have*

$$m_0(T) = \prod_{j=1}^k m(T_j), \quad (4.4)$$

$$m_1(T) = m_0(T) \cdot \sum_{j=1}^k \frac{m_0(T_j)}{m(T_j)}. \quad (4.5)$$

Proof. If (T, r) is of order 1, then there are no branches, and the product in (4.4) and the sum in (4.5) are empty, which coincides with the values for L given in (4.3). Thus we may focus on the case that the order of (T, r) is at least 2.

As $T-r$ consists of the connected components T_1, \dots, T_k , we clearly have $\mu(T-r) = \sum_{i=1}^k \mu(T_i)$ and (4.4). Furthermore,

$$\mu(T) = \max\left(\{\mu(T-r)\} \cup \left\{1 + \mu(T_j - r_j) + \sum_{i \neq j} \mu(T_i) : j \in \{1, \dots, k\}\right\}\right),$$

as a maximum matching either does not cover r or contains the edge rr_j for some j .

If all branches are of type B , i.e., $\mu(T_j - r_j) = \mu(T_j) - 1$ for all j , then $1 + \mu(T_j - r_j) + \sum_{i \neq j} \mu(T_i) = \sum_i \mu(T_i) = \mu(T-r)$ for all j . This implies that $\mu(T) = \mu(T-r)$, T is of type A and each of the edges rr_j can be used in a maximum matching.

If all branches are of type A , i.e., $\mu(T_j - r_j) = \mu(T_j)$ for all j , then $1 + \mu(T_j - r_j) + \sum_{i \neq j} \mu(T_i) = 1 + \sum_i \mu(T_i) = 1 + \mu(T-r)$ for all j . This implies that $\mu(T) = \mu(T-r) + 1$, T is of type B and again, each of the edges rr_j can be used in a maximum matching.

There are $m(T_1) \dots m(T_{j-1})m_0(T_j)m(T_{j+1}) \dots m(T_k)$ maximum matchings of T containing the edge rr_j . Summing over all j yields (4.5). \square

If T_1, \dots, T_k are rooted trees of type A , then the rooted tree with branches T_1, \dots, T_k is also denoted by $\mathcal{B}(T_1, \dots, T_k)$. It is of type B by Lemma 4.11.

Similarly, if T_1, \dots, T_k are rooted trees of type B , then the rooted tree with branches T_1, \dots, T_k is also denoted by $\mathcal{A}(T_1, \dots, T_k)$. It is of type A by Lemma 4.11. If $k = 1$, we will omit the parentheses and simply write $\mathcal{A}T_1$.

The crucial quantity in our investigation will be the following quotient:

Definition 4.12. For a rooted tree (T, r) , we set $\rho(T) = m_0(T)/m(T)$.

We note that by definition, $\rho(T) > 0$ for all rooted trees (T, r) .

We now reformulate the recursive formulæ for m and m_0 to yield recursive formulæ for ρ .

Lemma 4.13. *Let (T, r) be a rooted tree fulfilling the bipartition condition with branches $(T_1, r_1), \dots, (T_k, r_k)$. Then*

$$\rho(T) = \begin{cases} \frac{1}{1 + \sum_{j=1}^k \rho(T_j)}, & \text{if } (T, r) \text{ is of type } A, \\ \frac{1}{\sum_{j=1}^k \rho(T_j)}, & \text{if } (T, r) \text{ is of type } B. \end{cases}$$

Proof. This is a simple consequence of (4.4) and (4.5). □

4.3. α -optimality. It turns out that a rooted subtree of an optimal tree no longer needs to be optimal. Instead, we introduce the auxiliary notion of α -optimality.

Definition 4.14. Let α be a non-negative real number. A rooted tree (T, r) is said to be α -optimal if it fulfils the bipartition condition and if

$$m(T) + \alpha m_0(T) = \max\{m(T') + \alpha m_0(T') : (T', r') \text{ is a rooted tree fulfilling the bipartition condition with } |T| = |T'| \text{ and } \text{type}(T) = \text{type}(T')\}. \quad (4.6)$$

Note that 0-optimality is just ordinary optimality. This definition is motivated by the fact that any rooted subtree of an optimal tree is indeed α -optimal for an appropriate value of α :

Proposition 4.15. *Let T be an optimal tree, st an edge of T and T_s and T_t the connected components of $T - st$, with $s \in T_s$ and $t \in T_t$. Then (T_s, s) is a $\rho(T_t)$ -optimal tree and (T_t, t) is a $\rho(T_s)$ -optimal tree.*

Proof. If the order of T is ≤ 2 , the statement holds trivially.

Reformulating (4.2) in terms of the function ρ shows that

$$m(T) = m(T_t)(m(T_s) + \rho(T_t)m_0(T_s)).$$

If T_s was not $\rho(T_t)$ -optimal, we could replace it by a $\rho(T_t)$ -optimal tree and this would increase $m(T)$, contradiction. The same argument applies to T_t . □

We note the fact that $\rho(T) \leq 1$ holds for all rooted trees of type A by Lemma 4.13, where equality holds if and only if $T = L$. Thus, by Proposition 4.15, we may restrict ourselves to the investigation of α -optimal trees of type A with $\alpha \in [0, \infty)$ as well as α -optimal trees of type B with $\alpha \in [0, 1]$.

A few rooted trees will be considered repeatedly in our proofs. These are shown in Figure 8. One could indeed show that these trees are α -optimal for some $\alpha > 0$, but we do not need this information. On the other hand, we will later need to know that some rooted trees are not α -optimal for some ranges of α . We list these trees (together with a replacement T') in Table 3 in the appendix. Similarly, we list a few non-optimal trees in Table 2, where T_n^* is given in Theorem 3.3. We will simply refer to the entries of these two tables by (R1) to (R11). These tables can be verified using a Sage [20] program available in [11].

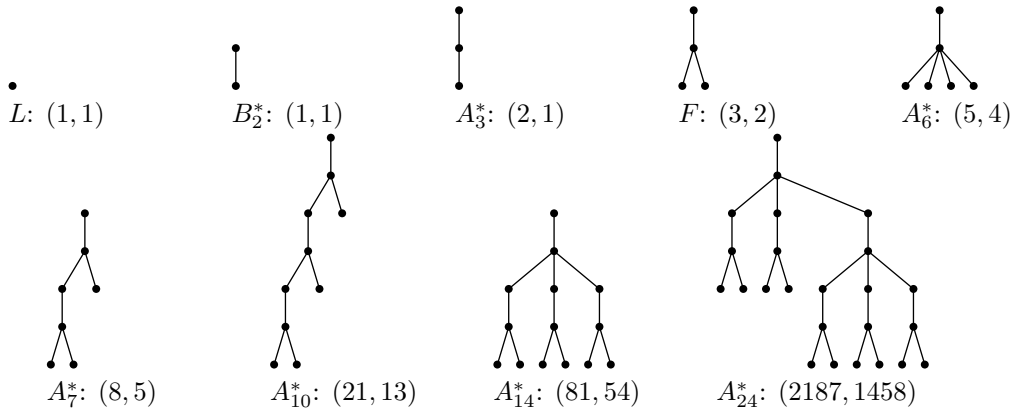

FIGURE 8. Some important rooted trees. All trees are given with the pair $(m(T), m_0(T))$.

4.4. Exchanging Subtrees. In order to derive information on the structure of optimal trees, we will compare optimal trees with trees where some rooted subtrees have been exchanged. In order to estimate the effect of such exchange operations, we need an extension of our recursive formulæ (4.4) and (4.5) to finer decompositions of a tree. These extensions will be formulated in terms of continuants and continued fractions.

We therefore fix some notations and definitions in the context of continuants and continued fractions. We follow Graham, Knuth and Patashnik [6], Section 6.7.

Definition 4.16 ([6, (6.127)]). The *continuant polynomial* $K_n(x_1, \dots, x_n)$ has n parameters, and it is defined by the following recurrence:

$$K_n(x_1, \dots, x_n) = K_{n-1}(x_1, \dots, x_{n-1})x_n + K_{n-2}(x_1, \dots, x_{n-2}) \tag{4.7}$$

for $n \geq 2$ and $K_0() = 1$, $K_1(x_1) = x_1$.

We will omit the index n in K_n whenever it is clear from the context.

We need the following additional properties of continuants:

Lemma 4.17. *We have*

$$K(x_1, \dots, x_n) = K(x_n, \dots, x_1) \tag{4.8}$$

$$K_n(x_1, \dots, x_n) = x_1 K_{n-1}(x_2, \dots, x_n) + K_{n-2}(x_3, \dots, x_n), \tag{4.9}$$

Proof. The symmetry relation (4.8) is [6, (6.131)], the recursion (4.9) is a consequence of the symmetry relation (4.8) and the defining recursion (4.7), cf. [6, (6.132)]. \square

The following lemma shows how continuants can be used to determine $m(T)$. We use the Iversonian notation $[expr] = 1$ if $expr$ is true and $[expr] = 0$ otherwise, cf. Knuth [14].

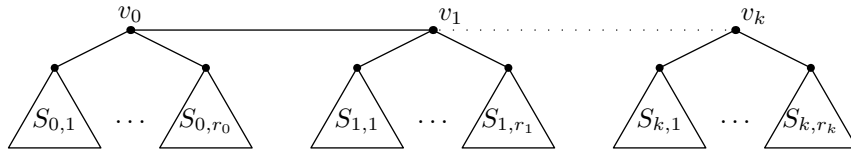

FIGURE 9. Shape of T for the exchange lemma.

Lemma 4.18. *Let T be a tree fulfilling the bipartition condition of the shape given in Figure 9 for some $k \geq 0$, integers $r_i \geq 0$ for $0 \leq i \leq k$, and rooted trees $S_{i,j}$, $0 \leq i \leq k$, $1 \leq j \leq r_i$.*

Then

$$m(T) = K(\rho_0, \rho_1, \dots, \rho_{k-1}, \rho_k) \prod_{h=0}^k \prod_{j=1}^{r_h} m(S_{h,j}),$$

where

$$\rho_i = [\text{type } v_i = A] + \sum_{j=1}^{r_i} \rho(S_{i,j}).$$

Proof. We set

$$M_i = \prod_{h=i}^k \prod_{j=1}^{r_h} m(S_{h,j})$$

and consider v_0 as root of T . We claim that

$$\begin{aligned} m(T(v_i)) &= M_i K(\rho_i, \rho_{i+1}, \dots, \rho_{k-1}, \rho_k), \\ m_0(T(v_i)) &= M_i K(\rho_{i+1}, \dots, \rho_{k-1}, \rho_k) \end{aligned}$$

holds for $0 \leq i \leq k$. This can be shown by reverse induction on i using only the recursive formulæ (4.4), (4.5) and (4.9). \square

We now turn to continued fractions.

Definition 4.19. We set

$$\text{CF}(x_0, x_1, \dots, x_n) = x_0 + \frac{1}{x_1 + \frac{1}{x_2 + \frac{1}{\ddots + \frac{1}{x_n}}}}.$$

As usual, for a sequence $(x_k)_{k \geq 0}$, the infinite continued fraction $\text{CF}(x_0, x_1, \dots)$ is defined as the limit $\lim_{k \rightarrow \infty} \text{CF}(x_0, x_1, \dots, x_k)$.

The connection between continuants and continued fractions is stated in the following result.

Lemma 4.20 ([6, (6.136)]). *We have*

$$\text{CF}(x_0, x_1, \dots, x_n) = \frac{K(x_0, x_1, \dots, x_n)}{K(x_1, \dots, x_n)}.$$

We are now able to formulate our main exchange lemma. It comes in several flavours: First, the most general version is stated, which might be cumbersome to use. Next, in a mostly symmetric case, we get a neat formulation, which will be frequently used. Finally, we give two estimates for the asymmetric case, which are not best possible, but sufficient for our purposes. For these estimates, we make some assumptions on the occurring values of ρ which will be fulfilled in the applications later on.

Lemma 4.21. *Let T be an optimal tree of the shape given in Figure 9 for some even $k \geq 2$, integers $r_i \geq 0$ for $0 \leq i \leq k$, and rooted trees $S_{i,j}$, $0 \leq i \leq k$, $1 \leq j \leq r_i$. We set*

$$\rho_i = [\text{type } v_i = A] + \sum_{j=1}^{r_i} \rho(S_{i,j}).$$

Let $0 \leq s_0 \leq r_0$ and $0 \leq s_k \leq r_k$ and set

$$\begin{aligned} x &:= \sum_{j=1}^{s_0} \rho(S_{0,j}), & y &:= \sum_{j=1}^{s_k} \rho(S_{k,j}), \\ a &:= [\text{type } v_0 = A] + \sum_{j=s_0+1}^{r_0} \rho(S_{0,j}), & b &:= [\text{type } v_k = A] + \sum_{j=s_k+1}^{r_k} \rho(S_{k,j}) \end{aligned}$$

so that $\rho_0 = x + a$ and $\rho_k = y + b$. Assume that $y + a > 0$, $x + b > 0$ and $\rho_1, \rho_{k-1} > 0$.

(1) If $x > y$, then

$$\text{CF}(a, \rho_1, \rho_2, \dots, \rho_{k-2}, \rho_{k-1}) \leq \text{CF}(b, \rho_{k-1}, \rho_{k-2}, \dots, \rho_2, \rho_1). \quad (4.10)$$

- (2) If $x > y$ and $(\rho_1, \dots, \rho_{k-1}) = (\rho_{k-1}, \dots, \rho_1)$, then $a \leq b$.
(3) If $x > y$, $\rho_j = 1$ for odd j and $\ell \leq \rho_j \leq u$ for all even j with $2 \leq j \leq k-2$ and for fixed $0 < \ell \leq u$, then

$$a < b + U_0(\ell, u),$$

where

$$U_0(\ell, u) = \frac{1}{\text{CF}(1, u, 1, u, 1)} - \frac{1}{\text{CF}(1, \ell, 1, \ell, \dots)}.$$

In particular, we have

$$U_0(1, 2) < 0.1153, \quad U_0(2, 3) < 0.0597, \quad U_0(3, 4) < 0.0373.$$

- (4) If $x > y$, $\rho_j = 1$ for even j with $2 \leq j \leq k-2$ and $\ell \leq \rho_j \leq u$ for all odd j and for fixed $0 \leq \ell \leq u$, then

$$a < b + U_1(\ell, u),$$

where

$$U_1(\ell, u) = \frac{1}{\text{CF}(\ell, 1, \ell)} - \frac{1}{\text{CF}(u, 1, u, 1, \dots)}.$$

In particular, we have

$$U_1(1, 2) < 0.3007, \quad U_1(2, 3) < 0.1113, \quad U_1(3, 4) < 0.0596.$$

Proof. (1) Set $M = \prod_{h=0}^k \prod_{j=1}^{r_h} m(S_{h,j})$ and let T' be the tree arising from T by exchanging $S_{0,1}, \dots, S_{0,s_0}$ against $S_{k,1}, \dots, S_{k,s_k}$. As k is even and $a + y > 0$ and $b + x > 0$, the types of all v_j are the same in T and T' . As T is an optimal tree, we have

$$\begin{aligned} 0 &\leq \frac{m(T) - m(T')}{M} \\ &= \mathbf{K}(x + a, \rho_1, \dots, \rho_{k-1}, y + b) - \mathbf{K}(y + a, \rho_1, \dots, \rho_{k-1}, x + b) \\ &= ((x + a)(y + b) - (y + a)(x + b)) \mathbf{K}(\rho_1, \dots, \rho_{k-1}) \\ &\quad + ((x + a) - (y + a)) \mathbf{K}(\rho_1, \dots, \rho_{k-2}) \\ &\quad + ((y + b) - (x + b)) \mathbf{K}(\rho_2, \dots, \rho_{k-1}) \\ &= (x - y) \mathbf{K}(\rho_1, \dots, \rho_{k-1}) \left(b - a + \frac{\mathbf{K}(\rho_1, \dots, \rho_{k-2})}{\mathbf{K}(\rho_1, \dots, \rho_{k-2}, \rho_{k-1})} - \frac{\mathbf{K}(\rho_2, \dots, \rho_{k-1})}{\mathbf{K}(\rho_1, \rho_2, \dots, \rho_{k-1})} \right) \\ &= (x - y) \mathbf{K}(\rho_1, \dots, \rho_{k-1}) \left(b - a + \frac{1}{\text{CF}(\rho_{k-1}, \dots, \rho_1)} - \frac{1}{\text{CF}(\rho_1, \dots, \rho_{k-1})} \right) \\ &= (x - y) \mathbf{K}(\rho_1, \dots, \rho_{k-1}) (\text{CF}(b, \rho_{k-1}, \dots, \rho_1) - \text{CF}(a, \rho_1, \dots, \rho_{k-1})) \end{aligned}$$

by Lemma 4.18, (4.7), (4.9), (4.8), Lemma 4.20 and the obvious recursion formula for continued fractions. The result follows upon division by the positive quantity $(x - y) \mathbf{K}(\rho_1, \dots, \rho_{k-1})$.

- (2) The symmetry implies that $\text{CF}(\rho_{k-1}, \dots, \rho_1) = \text{CF}(\rho_1, \dots, \rho_{k-1})$ and the result follows from (4.10).
(3) If $k \leq 4$, then the assertion follows from Lemma 4.21 (2). So we may assume $k \geq 6$. By (4.10) we have

$$\begin{aligned} a + \frac{1}{\text{CF}(1, \ell, 1, \ell, \dots)} &= \text{CF}(a, 1, \ell, 1, \ell, \dots) < \text{CF}(a, 1, \ell, \dots, \ell, 1) \\ &\leq \text{CF}(a, 1, \rho_2, \dots, \rho_{k-2}, 1) \\ &\leq \text{CF}(b, 1, \rho_{k-2}, 1, \rho_{k-4}, 1, \dots, \rho_2, 1) \\ &\leq \text{CF}(b, 1, u, 1, u, 1, \dots, u, 1) \\ &\leq \text{CF}(b, 1, u, 1, u, 1) = b + \frac{1}{\text{CF}(1, u, 1, u, 1)}, \end{aligned}$$

as decreasing the entries at even-numbered indices of a continued fraction $\text{CF}(x_0, x_1, \dots)$ decreases the continued fraction, and increasing entries at odd-numbered indices also decreases the continued fraction.

- (4) If $k \leq 2$, then the assertion follows from Lemma 4.21 (2). So we may assume $k \geq 4$. By (4.10) we have

$$\begin{aligned} a + \frac{1}{\text{CF}(u, 1, u, 1, \dots)} &= \text{CF}(a, u, 1, u, 1, \dots) < \text{CF}(a, u, 1, \dots, 1, u) \\ &\leq \text{CF}(a, \rho_1, 1, \dots, 1, \rho_{k-1}) \leq \text{CF}(b, \rho_{k-1}, 1, \dots, 1, \rho_1) \\ &\leq \text{CF}(b, \ell, 1, \ell) = b + \frac{1}{\text{CF}(\ell, 1, \ell)}. \end{aligned}$$

□

This exchange lemma will be used repeatedly in the following to deduce information about the structure of optimal trees. To simplify explanations, we will call the vertices v_0 and v_k in Figure 9 *pivotal vertices*.

5. THE UPPER BOUND: LOCAL STRUCTURE

We have now gathered enough auxiliary tools to start with the proof of Theorem 3.3 and thus Theorem 1.2. To abbreviate some statements, we introduce the following definitions.

Definition 5.1. Let T be a tree. We say that it fulfils the *local conditions* (LC), if all of the following conditions are fulfilled:

- (LC1) T fulfils the bipartition condition,
- (LC2) each vertex of type A has degree 1 or 2,
- (LC3) each vertex of type B has degree at least 3,
- (LC4) each vertex of degree 3 is adjacent to at least two leaves,
- (LC5) each vertex has degree at most 4,
- (LC6) no vertex is adjacent to 3 leaves.

By Proposition 4.7, an optimal tree of order ≥ 3 fulfils LC1.

The following theorem will be shown step by step in Sections 5.1, 5.2 and 5.3:

Theorem 5.2. Let $\mathcal{S} = \{T_2^*, T_3^*, T_5^*, T_{6,1}^*, T_{6,2}^*, T_8^*, T_9^*, T_{10}^*, T_{12}^*, T_{13}^*, T_{16}^*, T_{20}^*\}$ and T be an optimal tree with $T \notin \mathcal{S}$.

Then T fulfils the local conditions LC1–LC6.

We note that it is debatable whether LC6 shall be considered to be part of the *local structure* as $T_8^*, T_9^*, T_{12}^*, T_{16}^*$ fulfil LC1–LC5 and are contained in the generic cases described in Theorem 3.3. So these trees may simply be seen as degenerated cases of the generic cases even though LC6 is violated. On the other hand, T_{13}^* and T_{20}^* fulfil LC1–LC5, but not LC6, and these two trees are not contained in one of the generic families of Theorem 3.3. Since the overall proof is simpler when excluding the trees in \mathcal{S} at this stage, this is the route we proceed on.

5.1. Vertices of type A and estimates for vertices of type B . We first aim to show that almost all optimal trees fulfil LC2 and LC3. As a first step, we will show that almost all rooted subtrees of optimal trees contain a k -claw for $k \in \{2, 3, 4\}$, i.e., a rooted subtree with k branches all of which are single vertices, see Figure 13(a). In a second step, the existence of k -claws will provide us with bounds for $\rho(S)$ for rooted subtrees S of optimal trees. These bounds will be quite weak, but sufficient for using our general exchange lemma (Lemma 4.21) to give a useful technical result on decompositions of optimal trees along a path. This almost immediately yields LC2. We then characterise all optimal trees containing a B_2^* or a 4-claw as a rooted subtree (there are only very few), such that from the end of this subsection, we can work exclusively with 2- and 3-claws.

Lemma 5.3. Let S be a rooted subtree of an optimal tree $T \neq T_{6,2}^*$. Then S is isomorphic to L , A_3^* , B_2^* or it contains a k -claw for some $k \geq 2$, i.e., a rooted subtree as in Figure 13(a).

Proof. If $|S| \leq 2$, then $S \in \{L, B_2^*\}$ and there is nothing to show. We assume that $|S| > 2$ and that S does not contain a k -claw for any $k \geq 2$.

Let v_1 be a leaf of S of maximum height. Then v_1 is of type A . If its parent v_2 (which is of type B) has other branches, they have to be leaves by the choice of v_1 and we found a k -claw for $k \geq 2$, contradiction. Thus v_2 has only one branch, v_1 .

The parent of v_2 is called v_3 . It has to be of type A . So all branches of v_3 are of type B , thus they cannot be leaves. By construction, all branches of v_3 are isomorphic to B_2^* , cf. Figure 10(a).

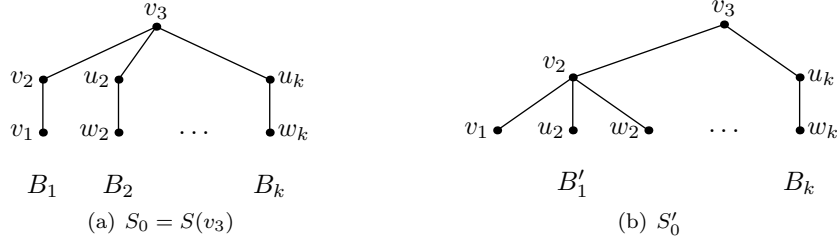

FIGURE 10. Shape of $S_0 = S(v_3)$ and S'_0 in the proof of Lemma 5.3.

Denote the branches of the rooted tree $S_0 := S(v_3)$ by B_1, B_2, \dots, B_k and assume that $k \geq 2$. Then we have $m_0(B_j) = 1$ and $m(B_j) = 1$. Thus $m_0(S_0) = 1$ and $m(S_0) = k + 1$. If we remove B_2 and add the two vertices as children of v_2 , cf. Figure 10(b), the resulting branch B'_1 has $m_0(B'_1) = 1$ and $m(B'_1) = 3$. The modified tree S'_0 has $m_0(S'_0) = 3$ and $m(S'_0) = 3(1 + k - 2 + 1/3) = 3k - 2 \geq k + 2 > m(S_0)$, contradiction to Proposition 4.15. Thus v_3 has only one child.

If $S = S_0$, then $S = A_3^*$ and there is nothing to show. Otherwise, the parent of v_3 is called v_4 . Then T has the shape shown in Figure 11 for some $k \geq 0$ and rooted trees A_0, \dots, A_k of type A .

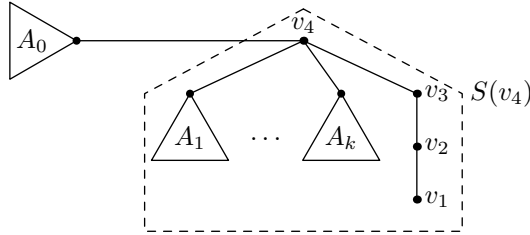

FIGURE 11. Shape of $S(v_4)$ in the proof of Lemma 5.3.

Each of the A_j , $j \in \{1, \dots, k\}$ is either a leaf (with $\rho(A_j) = 1$) or an A_3^* with $\rho(A_j) = 1/2$. As $\rho(A_0) > 0$, Lemma 4.21 (2) (with v_4 and v_2 as pivotal vertices) yields $\rho(A_1) + \dots + \rho(A_k) \leq 1$, i.e., either $k \leq 1$ or $k = 2$ and both A_1 and A_2 are isomorphic to A_3^* . Thus $S(v_4)$ is one of the trees in Figure 12. The trees S_1, S_3, S_4 are not α -optimal for any $\alpha \in [0, 1]$, cf. (R4), contradiction to



FIGURE 12. $S(v_4)$ in the proof of Lemma 5.3.

Proposition 4.15. The tree S_2 is not α -optimal for $\alpha < 1$, cf. (R4), so we must have $\rho(A_0) = 1$ and therefore $A_0 = L$. Thus we must have $T = T_{6,2}^*$, which has been excluded. \square

Knowing now that almost every rooted subtree of an optimal tree contains a k -claw with $k \geq 2$, we show that no k -claws with $k \geq 5$ occur.

Lemma 5.4. *For $k \geq 5$, a k -claw does not occur as rooted subtree of an optimal tree.*

Proof. Let (T, b) be a k -claw, cf. Figure 13(a), and (T', b) be the rooted tree in Figure 13(b) of the same order and type.



FIGURE 13. k -claw and tree T' for the proof of Lemma 5.4

We have

$$\begin{aligned} m_0(T) &= 1^k = 1, & m(T) &= m_1(T) = 1(1 + \dots + 1) = k, \\ m_0(T') &= 3 \cdot 1^{k-4} = 3, & m(T') &= m_1(T') = 3 \left(\frac{2}{3} + (k-4) \right) = 3k - 10. \end{aligned}$$

For $k \geq 5$, we have $m(T') \geq k = m(T)$ and $m_0(T') = 3 > 1 = m_0(T)$, thus T cannot be α -optimal for any $\alpha > 0$, so it is not a subtree of an optimal tree by Proposition 4.15. \square

We are now able to prove lower bounds for $\rho(S)$ for rooted subtrees S of optimal trees. The key idea is the following: Changing the root of S to another root can only alter $m_0(S)$, but $m(S)$ remains unchanged. Changing the root of S cannot increase $\rho(S)$, since this would increase $m(S) + \alpha m_0(S)$, contradiction to the α -optimality of S . The new roots used for comparison will be leaves or roots of k -claws.

We start with lower bounds for rooted subtrees of type A .

Lemma 5.5. *Let S be a rooted subtree of type A of an optimal tree T . Then $\rho(S) \geq 1/2$ with equality if and only if $S = A_3^*$.*

Proof. Let T consist of the rooted subtrees (S, s) and (T_t, t) of types A and B , respectively, and of the edge st .

For $|S| \leq 3$, we have $S \in \{L, A_3^*\}$ and there is nothing to show, so we assume $|S| > 3$.

By Lemmata 5.3 and 5.4, S contains an ℓ -claw for some $2 \leq \ell \leq 4$. We switch the root of S to a leaf of the ℓ -claw, obtaining a new rooted tree (S', a_1) shown in Figure 14. The rooted tree

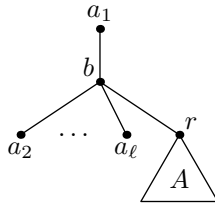

FIGURE 14. Tree S' in the proof of Lemma 5.5

(A, r) arises from the rooted connected component T_r of $T - br$ by removing the rooted subtree T_t of type B . Removing a rooted subtree of type B from a rooted tree of type A fulfilling the bipartition condition for rooted trees yields a rooted tree of type A , so A is of type A .

The $\rho(T_t)$ -optimality of S together with $m(S) = m(S')$ implies that

$$\rho(S) \geq \rho(S') = \frac{1}{1 + \frac{1}{\ell-1+\rho(A)}} > \frac{1}{1 + \frac{1}{1}} = \frac{1}{2}.$$

□

We are now able to prove a lower bound for $\rho(S)$ for rooted subtrees S of type B .

Lemma 5.6. *Let (S, r) be a rooted subtree of type B of an optimal tree T with $|T| \geq 3$. If S contains a k -claw for some $k \geq 1$, then $\rho(S) \geq \frac{1}{1+k}$.*

Proof. By Proposition 4.7, T and S fulfil the bipartition condition and the bipartition condition for rooted trees, respectively.

If S has only one branch, say $S = \mathcal{B}(S')$, then S' is of type A by the bipartition condition for rooted trees and $\rho(S') \leq 1$. Thus $\rho(S) = 1/\rho(S') \geq 1$, as required. So we assume that S has more than one branch.

If S is the k -claw, then $\rho(S) = 1/k > 1/(k+1)$.

Let T consist of the rooted subtrees (S, r) and (T_t, t) of types B and A , respectively, and of the edge rt .

We change the root of S to the root of the k -claw, which results in a rooted tree (S', s) with $m(S) = m(S')$ shown in Figure 15. Here A arises from a rooted subtree of T of type A by

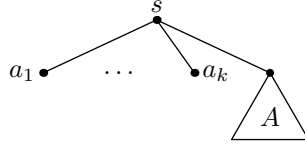

FIGURE 15. Tree S' in the proof of Lemma 5.6

removing the rooted subtree (T_t, t) . Since it was assumed that S has more than one branch, we conclude that A is still of type A by Lemma 4.11 and that $\rho(A) \leq 1$. As S is $\rho(T_t)$ -optimal by Proposition 4.15, this yields

$$\rho(S) \geq \rho(S') = \frac{1}{k + \rho(A)} \geq \frac{1}{k + 1}.$$

□

Next, we give a preliminary upper bound for $\rho(S)$ for rooted subtrees of type A :

Lemma 5.7. *Let S be a rooted subtree of type A of an optimal tree T . Then $S = L$ or $\rho(S) \leq 5/6$.*

Proof. Assume that $S \neq L$. Let $S = \mathcal{A}(B_1, \dots, B_\ell)$ for suitable branches B_1, \dots, B_ℓ for some $\ell \geq 1$. By Lemmata 5.6, 5.3 and 5.4, we have $\rho(B_1) \geq 1/5$, which implies

$$\rho(S) = \frac{1}{1 + \rho(B_1) + \dots + \rho(B_\ell)} \leq \frac{1}{1 + \rho(B_1)} \leq \frac{5}{6}.$$

□

We have now collected the necessary (weak) bounds for $\rho(S)$ for rooted subtrees of optimal trees. These suffice for the following path decomposition lemma, using the exchange lemma (Lemma 4.21) to derive bounds for ρ_i along a path (as in Figure 9) when the two ends of the path are roots of claws.

Lemma 5.8. *Let T be an optimal tree of the shape as in Figure 9 for some even $k \geq 2$ with $S_{0,1} = \dots = S_{0,r_0} = L$, $S_{k,1} = \dots = S_{k,r_k} = L$, i.e., v_0 and v_k are the roots of an r_0 -claw and an r_k -claw, respectively. We assume that $r_0 \geq r_k \geq 1$ and $r_0 \geq 2$ and set*

$$\rho_i = [\text{type } v_i = A] + \sum_{j=1}^{r_i} \rho(S_{i,j}).$$

Then v_i is of type A and $(\rho_i, r_i) = (1, 0)$ for odd i and $r_0 - 1 \leq \rho_i \leq r_k$ for even i with $0 < i < k$. In particular, we have $r_0 \leq r_k + 1$.

Proof. By the bipartition condition and the fact that v_0 and v_k are the roots of an r_0 -claw and an r_k -claw, respectively, we conclude that v_i is of type A for odd i and of type B for even i . We define the rooted trees (R, v_0) and (L, v_k) as two rooted versions of T , so that the notations $R(v_i)$ and $L(v_i)$ are defined.

We prove the lemma by induction on i , where we first only prove that

$$v_i \text{ is of type } A \text{ and } (\rho_i, r_i) = (1, 0) \text{ for odd } i \text{ and } r_0 - 1 \leq \rho_i \leq r_0 \text{ for even } i \text{ with } 0 < i < k, \quad (5.1)$$

i.e., we relax the upper bound for ρ_i in the case of even i .

We first consider the case of odd i , i.e., v_i is of type A . If $\rho_i > 1$, we conclude that $\rho(R(v_{i+1})) < 0 + U_1(r_0 - 1, r_0)$ from Lemma 4.21 (4) (with v_i and $S_{0,1} = L$ as pivotal vertices). By Lemma 5.6, we have $\rho(R(v_{i+1})) \geq 1/(r_k + 1) \geq 1/(r_0 + 1)$. As $U_1(d - 1, d) < 1/(d + 1)$ for $d \in \{2, 3, 4\}$, this is a contradiction. So $\rho_i = 1$ and therefore $r_i = 0$.

Next, we consider the case of even i , i.e., v_i is of type B . If $\rho_i > \rho_0 = r_0$, then Lemma 4.21 (3) (now with v_i and v_0 as pivotal vertices) yields $\rho(R(v_{i+1})) \leq U_0(r_0 - 1, r_0) \leq 0.1153$, a contradiction to Lemma 5.5. Thus we have $\rho_i \leq \rho_0 = r_0$.

For the lower bound on ρ_i , we assume that $\rho_i < r_0 - 1 = \rho(S_{0,2}) + \dots + \rho(S_{0,r_0})$. Then Lemma 4.21 (3) implies $1 = \rho(S_{0,1}) \leq \rho(R(v_{i+1})) + U_0(r_0 - 1, r_0) < \rho(R(v_{i+1})) + 0.1153$. As $\rho(R(v_{i+1})) \leq 5/6$ by Lemma 5.7, this is a contradiction. This concludes the proof of (5.1).

Finally, $r_i \leq r_k$ is again a consequence of Lemma 4.21 (3), as $\rho(L(v_{i-1})) \geq 1/2 > 0.1153$.

If $k > 2$, then $r_0 - 1 \leq r_2 \leq r_k$. If $k = 2$, then Lemma 4.21 (2) and $\rho(S_{0,r_0}) > 0$ imply that $r_0 - 1 = \rho(S_{0,1}) + \dots + \rho(S_{0,r_0-1}) \leq \rho(S_{0,1}) + \dots + \rho(S_{0,r_k}) = r_k$, as required. \square

Combining the description of rooted subtrees without any k -claw with $k \geq 2$ with the path decomposition lemma (Lemma 5.8) shows that B_2^* is forbidden in almost all optimal trees.

Lemma 5.9. *Suppose that B_2^* is a rooted subtree of an optimal tree T . Then $T \in \{T_3^*, T_{6,2}^*\}$.*

Proof. Assume first that T does not contain an ℓ -claw for any $\ell \geq 2$. As T contains a B_2^* as a rooted subtree, we have $|T| \geq 3$. Consider a leaf s of T . Then by Proposition 4.7, the rooted subtree $T - s$ of T is of type B and therefore equals B_2^* by Lemma 5.3. We conclude that $T = T_3^*$.

So we may now assume that T contains an ℓ -claw with $\ell \geq 2$. Thus T can be decomposed as in Lemma 5.8 with $r_0 \geq \ell \geq 2$ and $r_k = 1$ for some $k \geq 2$. By Lemma 5.8, we have $r_0 \leq 1 + 1 = 2$, so $r_0 = 2$. If $k = 2$, then we have $T = T_{6,2}^*$.

So we may assume that $k > 2$. By Lemma 5.8 again, we have $\rho_{k-2} = 1$, which by Lemmata 5.5 and 5.7 implies that $r_{k-2} = 1$ with $S_{k-2,1} = L$ or $r_{k-2} = 2$ with $S_{k-2,1} = S_{k-2,2} = A_3^*$. Thus $R(v_{k-2})$ is a rooted subtree of T of type B and order at least 5 containing no ℓ -claw for any $\ell \geq 2$, contradiction to Lemma 5.3. \square

Remark 5.10. Having excluded B_2^* , we can also exclude the presence of A_3^* as a rooted subtree in the following, which will be important in many arguments.

As a direct consequence of the path decomposition lemma (together with the information that it can always be applied as B_2^* has now been excluded), we have shown LC2.

Proposition 5.11. *Let $T \neq T_2^*$ be an optimal tree. Then T fulfils LC1–LC2.*

Proof. Let v be a vertex of type A in T of degree at least 2. Then T may be represented as in Lemma 5.8 with $v = v_i$ for some odd i : choose a longest path that contains v . The ends of this path are leaves, their unique neighbours are the pivotal vertices v_0 and v_k . All but one of the neighbours of v_0 have to be leaves by the choice of the path, and there has to be more than one such neighbour in view of Lemma 5.9. The same applies to v_k . Hence $r_i = 0$ by Lemma 5.8, i.e., $\deg v = 2$. \square

We conclude this subsection by excluding 4-claws in almost all cases. To do so, we will use a direct substitution for those cases which are allowed by the path decomposition lemma.

Lemma 5.12. *Let T be an optimal tree containing a 4-claw as a rooted subtree. Then $T = T_{6,1}^*$.*

Proof. We denote the root of the 4-claw by w . The neighbour of w which is not contained in the 4-claw is denoted by v . By Proposition 5.11, T fulfils LC1–LC2. As w is of type B , v is of type A and $\deg v \leq 2$. If v is a leaf, then $T = T_{6,1}^*$ and we are done. So we assume the contrary and denote the neighbour of v different from w by u . Then T is of the shape shown in Figure 16(a), where A_1, \dots, A_ℓ denote some trees of type A with $\rho(A_1) \geq \rho(A_2) \geq \dots \geq \rho(A_\ell)$. If $A_1 = \dots = A_\ell = L$, then $\ell \in \{3, 4\}$ by Lemmata 5.4 and 5.8. Both cases do not lead to an optimal tree, cf. (R1).

So we may assume that $\rho(A_\ell) < 1$, whence Lemma 4.21 (2), with u and w as pivotal vertices, yields $\rho(A_1) + \dots + \rho(A_{\ell-1}) \geq 3$. Thus we have $\ell = 4$ and $A_1 = A_2 = A_3 = L$ or $\ell \geq 5$.

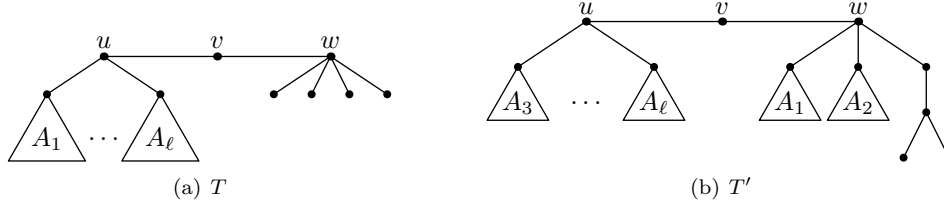

FIGURE 16. Trees considered in Lemma 5.12.

We consider the tree T' shown in Figure 16(b) of the same order as T . Using the abbreviations $a = \rho(A_3) + \dots + \rho(A_\ell)$, $b = \rho(A_1) + \rho(A_2)$ and $M = m(A_1) \dots m(A_\ell)$ as well as the optimality of T , Lemma 4.18 yields

$$\begin{aligned} M(5a + 5b + 4) &= MK(a + b, 1, 4) = m(T) \\ &\geq m(T') = 3MK\left(a, 1, b + \frac{2}{3}\right) = M(3ab + 5a + 3b + 2), \end{aligned}$$

which implies

$$2 \geq b(3a - 2).$$

As $b = \rho(A_1) + \rho(A_2) \geq 1$ and $a \geq 3/2$ (for $\ell \geq 5$ as well as for $\ell = 4$ and $\rho(A_3) = 1$) by Lemma 5.5, this is a contradiction. \square

5.2. Lower degree bounds for vertices of type B . We now want to show that almost all optimal trees fulfil LC1–LC4. In order to facilitate the discussion, we introduce the notion of a “light” vertex.

Definition 5.13. Let T be a tree fulfilling the bipartition condition and v a vertex of type B in T . Then v is said to be a *light vertex* if it has degree ≤ 3 and is adjacent to at most one leaf.

The sum of the ρ -values of the rooted connected components of $T - v$ is quite small for a light vertex v . The exchange lemma then forbids vertices whose rooted connected components have a high sum of ρ -values.

The path decomposition lemma can be used to derive a description of light vertices:

Lemma 5.14. *If $T \notin \{T_2^*, T_3^*, T_{6,2}^*\}$ is an optimal tree, then T fulfils LC1–LC3. If v is a light vertex of T , then $\deg v = 3$ and v is adjacent to exactly one leaf.*

Proof. If T has no light vertex, then T fulfils LC1–LC4. So we assume that v is a light vertex. Denote the rooted connected components of $T - v$ by T_0, \dots, T_{k-1} with $|T_0| \geq |T_1| \geq \dots \geq |T_{k-1}|$. As v is a light vertex, we have $k \leq 3$. If $|T_0| = 1$, i.e., $T_0 = \dots = T_{k-1} = L$, we have $k \leq 2$ and $T \in \{T_2^*, T_3^*\}$, which have been excluded. If $|T_1| = 1$, then v is the root of a $(k - 1)$ -claw. As v is light, we have $k = 2$, contradiction to Lemma 5.9.

So both T_0 and T_1 contain an ℓ_0 -claw and an ℓ_1 -claw, respectively, for some $\ell_0 \geq 2, \ell_1 \geq 2$ by Lemma 5.3 and Lemma 5.9. By Lemma 5.8, we obtain $\rho(T_2) + \dots + \rho(T_{k-1}) \geq 1$. As $k \leq 3$ by assumption, we have $\rho(T_2) + \dots + \rho(T_{k-1}) = \rho(T_2) \leq 1$, thus T_2 is a leaf, as required. \square

We now describe vertices of type B when a light vertex is present.

Lemma 5.15. *Let $T \notin \{T_2^*, T_3^*, T_{6,2}^*\}$ be an optimal tree, v be a light vertex and w be a vertex of type B of T . Then either $\deg w = 4$ and w is not adjacent to any leaf or $\deg w = 3$ and w is adjacent to one or two leaves.*

Proof. If w is light, then there is nothing to show by Lemma 5.14. Otherwise, either $\deg w \geq 4$ or $\deg w = 3$ and w is adjacent to two leaves, as required. So we now assume that $\deg w \geq 4$.

Denote the rooted connected components of $T - w$ by $T_0, \dots, T_{\ell-1}$ with $v \in T_0$ and $\rho(T_1) \geq \dots \geq \rho(T_{\ell-1})$. The rooted connected component of $T - v$ which does not contain w and is not a leaf is denoted by S . By Lemma 5.5, we have $\rho(T_{\ell-2}) + \rho(T_{\ell-1}) > \rho(L)$ (since A_3^* has been excluded). Now we make use of a combination of Lemma 5.8 and Lemma 4.21 (3)—the following argument will be used several times, so we only explain it in detail here: the path between v and w can be extended to a longest path ending in an r_0 - and an r_k -claw, with $2 \leq r_0, r_k \leq 3$ by Lemmata 5.9, 5.4 and 5.12. Application of Lemma 5.8 now shows that the vertices on the path between v and w satisfy the necessary conditions to make Lemma 4.21 (3) applicable (with v and w as pivotal vertices), which yields

$$\rho(T_1) + \dots + \rho(T_{\ell-3}) \leq \rho(S) + 0.1153. \quad (5.2)$$

From Lemmata 5.5 and 5.7, we obtain

$$\frac{\ell - 3}{2} < \rho(T_1) + \dots + \rho(T_{\ell-3}) \leq \rho(S) + 0.1153 \leq \frac{5}{6} + 0.1153 < 1,$$

which yields $\ell < 5$ and $\deg w = \ell = 4$. Furthermore, (5.2) together with Lemma 5.7 yields $\rho(T_1) \leq \frac{5}{6} + 0.1153 < 1$, i.e., $1 > \rho(T_1) \geq \rho(T_2) \geq \rho(T_3)$, so w is not adjacent to any leaf. \square

Light vertices correspond to low values of $\rho(A)$ for rooted subtrees of type A . This correspondence is described in the following two lemmata.

Lemma 5.16. *Let $T \notin \{T_2^*, T_3^*, T_{6,2}^*\}$ be an optimal tree and A be a rooted subtree of T of type A that contains no light vertex of T . Then*

$$\rho(A) \geq \frac{2}{3}$$

with equality for $A \in \{F, A_{14}^, A_{24}^*\}$.*

Proof. We prove the result by induction on the order of A . If A has order 1, then $\rho(A) = 1$.

Otherwise, $A = \mathcal{AB}(A_1, \dots, A_k)$ for suitable rooted trees A_1, \dots, A_k of type A by Proposition 5.11. As A does not contain any light vertex, we have $A = F$ with $\rho(A) = 2/3$ or $k \geq 3$.

We now turn to the case $k \geq 3$. We have $\rho(A_j) \geq 2/3$ by the induction hypothesis and therefore

$$\rho(A) = \frac{1}{1 + \frac{1}{\rho(A_1) + \dots + \rho(A_k)}} \geq \frac{1}{1 + \frac{1}{3 \cdot \frac{2}{3}}} = \frac{2}{3}.$$

Equality holds for $k = 3$ and $\rho(A_1) = \rho(A_2) = \rho(A_3) = 2/3$. By the induction hypothesis, we conclude that $A_1, A_2, A_3 \in \{F, A_{14}^*, A_{24}^*\}$. We have $A_{14}^* = \mathcal{AB}(F, F, F)$ and $A_{24}^* = \mathcal{AB}(F, F, A_{14}^*)$. Next, the two trees $\mathcal{AB}(F, F, A_{24}^*)$ and $\mathcal{AB}(F, A_{14}^*, A_{14}^*)$ are not α -optimal for $\alpha > 50/2473$, cf. (R5), whence they do not occur as rooted subtrees of optimal trees by Proposition 4.15 and Lemma 5.6. A further six cases have to be checked, but none of these is an α -optimal tree for any $\alpha \geq 0$, cf. again (R5). \square

Lemma 5.17. *Let $T \notin \{T_2^*, T_3^*, T_{6,2}^*\}$ be an optimal tree containing a light vertex and A be a rooted subtree of T of type A . Then A is a leaf or*

$$\rho(A) \leq \frac{2}{3},$$

where equality holds if and only if A does not contain a light vertex.

Proof. We prove the assertion by induction on the order of A . For $|A| > 1$, we have $A = \mathcal{AB}(A_1, \dots, A_k)$ for suitable rooted trees A_1, \dots, A_k . By Lemma 5.15, we have $k \in \{2, 3\}$.

If $k = 2$, then $\rho(A_1) + \rho(A_2) \leq 1 + 1 \leq 2$ where equality holds if and only if both A_1 and A_2 are leaves, i.e., A does not contain a light vertex.

If $k = 3$, then none of A_1, A_2, A_3 is a leaf by Lemma 5.15, so the induction hypothesis yields $\rho(A_1) + \rho(A_2) + \rho(A_3) \leq 2$ with equality if and only if none of A_1, A_2, A_3 contains a light vertex. In both cases, we get

$$\rho(A) = \frac{1}{1 + \frac{1}{\rho(A_1) + \dots + \rho(A_k)}} \leq \frac{1}{1 + \frac{1}{2}} = \frac{2}{3}.$$

□

We are now ready to prove local condition LC4.

Proposition 5.18. *Let T be an optimal tree containing a light vertex. Then $T \in \{T_2^*, T_3^*, T_{6,2}^*, T_{10}^*\}$. In other words, all optimal trees except $T_2^*, T_3^*, T_{6,2}^*, T_{10}^*$ fulfil LC1–LC4.*

Proof. We assume that $T \notin \{T_2^*, T_3^*, T_{6,2}^*\}$. As the tree in Figure 17 with root r is not α -optimal

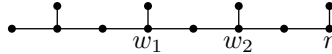

FIGURE 17. Subtree of T in Proposition 5.18.

for $\alpha < 7/6$, cf. (R6), and any vertex of degree 3 is adjacent to at least one leaf by Lemma 5.14, rooted subtrees S of type A of T containing a light vertex and no vertex of degree 4 are isomorphic to $A_7^* = \mathcal{AB}(L, F)$ or $A_{10}^* = \mathcal{AB}(L, A_7^*)$. (5.3)

By (R7), Lemma 5.17, Proposition 4.15 and the fact that T contains a light vertex, we see that

$$\text{neither } \mathcal{B}(L, A_{14}^*) \text{ nor } \mathcal{B}(L, A_{24}^*) \text{ occurs as a rooted subtree of } T. \quad (5.4)$$

Let now S be a rooted subtree of type A of T containing a vertex of degree 4 and a light vertex. We choose S in such a way that its order is minimal among all rooted subtrees with these properties. We write $S = \mathcal{AB}(S_1, \dots, S_d)$ for some $d \in \{2, 3\}$ (by Lemma 5.15).

We first consider the case $d = 2$. By Lemma 5.15, we have $S_1 = L$. As S contains a vertex of degree 4, so does S_2 . By minimality of S , S_2 does not contain a light vertex. By Lemmata 5.16 and 5.17, we have $\rho(S_2) = 2/3$ and therefore $S_2 \in \{A_{14}^*, A_{24}^*\}$, contradiction to (5.4).

Thus we are left with the case $d = 3$. By the minimality of S , each of the S_j either contains a light vertex and does not contain a vertex of degree 4, whence $S_j \in \{A_7^*, A_{10}^*\}$ by (5.3), or does not contain a light vertex, whence $S_j \in \{F, A_{14}^*, A_{24}^*\}$ by Lemmata 5.16 and 5.17.

We first consider the case that one of S_1, S_2, S_3 , say S_1 , is an A_{10}^* . Then T can be decomposed as in Figure 18(a) for some rooted tree S_0 of type A . As $\rho(S_0) + \rho(S_3) > \rho(L) = 1$, Lemma 4.21 (2)

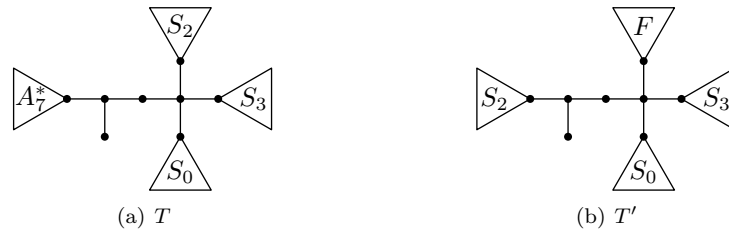

FIGURE 18. Decomposition of T and T' in Proposition 5.18.

yields $\rho(S_2) \leq \rho(A_7^*) < 2/3$. Analogously, we get $\rho(S_3) < 2/3$. Thus we have $\{S_2, S_3\} \subseteq \{A_7^*, A_{10}^*\}$. By (R8), $\mathcal{B}(S_1, S_2, S_3)$ is not $\rho(S_0)$ -optimal, contradiction to Proposition 4.15.

So we are left with the case that $\{S_1, S_2, S_3\} \subseteq \{F, A_7^*, A_{14}^*, A_{24}^*\}$. As S contains a light vertex, we may assume that $S_1 = A_7^*$. If $S_2 \in \{A_{14}^*, A_{24}^*\}$, we note that switching S_2 and the F of $S_1 = A_7^* = \mathcal{AB}(L, F)$ yields the tree T' shown in Figure 18(b) with $m(T) = m(T')$ by Lemma 4.18. But T' is not optimal by (5.4). We conclude that $\{S_2, S_3\} \subseteq \{F, A_7^*\}$. By (R9), Lemma 5.17 and Proposition 4.15, the only remaining case is $(S_0, S_1, S_2, S_3) = (L, A_7^*, F, F)$. This case is ruled out by (R2).

So there is no rooted subtree S of type A containing both a light vertex and a vertex of degree 4. By Lemmata 5.15 and 5.3, T contains a 2-claw. Removing this 2-claw from T yields a rooted tree S of type A of T containing a light vertex. We conclude that S does not contain a vertex of degree 4, thus $S \in \{A_7^*, A_{10}^*\}$ by (5.3). The case $S = A_7^*$ yields $T = T_{10}^*$, the case $S = A_{10}^*$ is impossible in view of (R6) (cf. Figure 17). \square

5.3. Upper degree bounds for vertices of type B . We now conclude the proof which shows that almost all optimal trees fulfil LC1–LC6.

If an optimal tree contains a 2-claw, the upper degree bound LC5 for degrees of type B is a consequence of the exchange lemma together with the improved lower bound for $\rho(S)$ for rooted subtrees S of type A obtained by the exclusion of light vertices.

Lemma 5.19. *Let $T \notin \{T_2^*, T_3^*, T_{6,2}^*, T_{10}^*\}$ be an optimal tree. If T contains a 2-claw as a rooted subtree, then T fulfils LC1–LC5.*

Proof. Assume that there is a vertex w of type B of degree $k \geq 5$. We denote the rooted connected components of $T - w$ by T_0, T_1, \dots, T_{k-1} , where a 2-claw is contained in T_0 . Now we combine Lemma 5.8 and Lemma 4.21 (3) as before: since $\rho(T_{k-1}) + \rho(T_{k-2}) > 1 = \rho(L)$ (where L is one of the leaves of the 2-claw contained in T_0), we have

$$\rho(T_1) + \rho(T_2) + \dots + \rho(T_{k-3}) < \rho(L) + 0.1153.$$

As T contains no light vertex by Proposition 5.18, Lemma 5.16 yields

$$\frac{2}{3}(k-3) < 1.1153.$$

We conclude that $k < 5$, as required. \square

We are now left with optimal trees containing 3-claws. The arguments are somewhat similar as in the case of light vertices, except that we now have to deal with “heavy” vertices.

Lemma 5.20. *Let T be an optimal tree containing a 3-claw and containing a vertex v of degree 4 which is adjacent to at most 2 leaves.*

Then v is adjacent to exactly 2 leaves. Furthermore, each vertex of degree $k > 4$ is adjacent to at most 2 leaves.

Proof. Denote the rooted connected components of $T - v$ by T_1, \dots, T_4 , where we assume that T_1 contains a 3-claw and T_4 is not a leaf. By Lemma 5.8, we have $\rho(T_2) + \rho(T_3) \geq 2$, i.e., T_2 and T_3 are indeed leaves.

We have therefore shown that every vertex of degree 4 is adjacent to 2 or 3 leaves.

Assume that w is a vertex of degree $k \geq 5$ in T . Still denoting the rooted connected components of $T - v$ by $T_1, T_2 = L, T_3 = L, T_4$, we may now assume that w is contained in T_4 (T_4 also contains a 3-claw, since otherwise Lemma 5.19 would apply, so we can interchange the roles of T_1 and T_4 if necessary). The rooted connected components of $T - w$ are denoted by S_0, S_1, \dots, S_{k-1} with the assumption that v is contained in S_0 and $\rho(S_1) \geq \rho(S_2) \geq \dots \geq \rho(S_{k-1})$. Combining Lemma 5.8 and Lemma 4.21 (3) again (with v and w as pivotal vertices and $\rho(S_{k-1}) > 0.1153$), we get

$$\rho(S_1) + \rho(S_2) + \rho(S_3) \leq \rho(S_1) + \rho(S_2) + \dots + \rho(S_{k-2}) \leq \rho(T_1) + \rho(T_2) + \rho(T_3) < 3,$$

which implies that $\rho(S_3) < 1$ and therefore w is adjacent to at most 2 leaves. \square

The lower bound in the following lemma is the same as in Lemma 5.16; but instead of considering a rooted subtree of an optimal tree, we only assume LC1–LC4.

Lemma 5.21. *Let T be a tree fulfilling LC1–LC4 and A be a rooted subtree of type A . Then*

$$\rho(A) \geq 2/3.$$

Proof. Analogous to Lemma 5.16. \square

We will exclude the occurrence of three or more 3-claws in an optimal tree by substituting two 3-claws by 2-claws and use the additional vertices in order to create a light vertex. To make this work, we have to analyse the effects of these substitutions. As the intermediate steps do not necessarily lead to optimal trees, we can only use the above bound.

Lemma 5.22. *Let T be a tree fulfilling LC1–LC4.*

- (1) *If one 3-claw in T is replaced by a 2-claw, we have $m(T')/m(T) \geq 8/11$ and $|T'| = |T| - 1$ for the resulting tree T' . Furthermore T' fulfils LC1–LC4.*
- (2) *If one 3-claw in T is replaced by a $\mathcal{B}(L, F)$, we have $m(T')/m(T) \geq 21/11$ and $|T'| = |T| + 2$ for the resulting tree T' .*

Proof. Let T consist of a 3-claw, a rooted tree S of type A and the edge connecting the root of the 3-claw and the root of S . We have $\rho(S) \geq 2/3$ by Lemma 5.21.

- (1) By Lemma 4.4, we have

$$\frac{m(T')}{m(T)} = \frac{1m_0(S) + 2m(S)}{1m_0(S) + 3m(S)} = \frac{\rho(S) + 2}{\rho(S) + 3} = 1 - \frac{1}{\rho(S) + 3} \geq 1 - \frac{1}{\frac{2}{3} + 3} = \frac{8}{11}.$$

- (2) Analogous.

□

We now deal with optimal trees containing a 3-claw. The restrictions are now so strict that we can discuss all cases.

Proposition 5.23. *Let T be an optimal tree which contains a 3-claw. Then $T \in \{T_5^*, T_8^*, T_9^*, T_{12}^*, T_{13}^*, T_{16}^*, T_{20}^*\}$.*

Proof. Assume that T contains 3 rooted subtrees isomorphic to a 3-claw. Replacing two of them by a 2-claw and the third by a $\mathcal{B}(L, F)$ yields a tree T' with $|T| = |T'|$ and

$$\frac{m(T')}{m(T)} \geq \frac{8}{11} \cdot \frac{8}{11} \cdot \frac{21}{11} > 1$$

by Lemma 5.22, contradiction.

We conclude that T contains at most 2 rooted subtrees isomorphic to a 3-claw.

We now assume that T has a vertex v of degree $k \geq 5$. By Lemma 5.19, T does not contain a 2-claw and thus no vertices of degree 3 by Proposition 5.18. Thus every rooted subtree of $T - v$ either contains a 3-claw or is a leaf by Lemmata 5.3, 5.4, 5.9 and 5.12. As there are at most 2 subtrees isomorphic to a 3-claw in T , there are at least $k - 2$ leaves. By Lemmata 5.4 and 5.12, we conclude that v is adjacent to exactly $k - 2$ leaves. Denote the rooted connected components of $T - v$ by T_1, T_2, L, \dots, L . By Lemma 5.8, we have

$$k - 2 = \rho(L) + \dots + \rho(L) \leq 3,$$

i.e., $k = 5$. By Lemma 5.20, we conclude that all vertices of degree 4 in T are adjacent to 3 leaves, i.e., they are the root of a 3-claw.

Thus T is of the shape given in Figure 19(a) for some $k \geq 1$ (as there is no vertex of degree

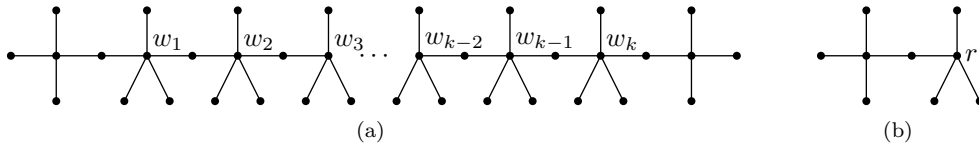
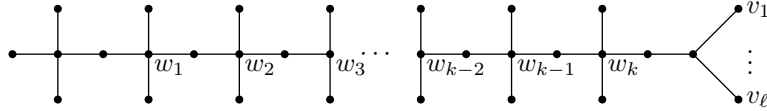
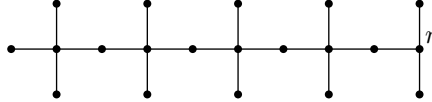

FIGURE 19. Shape of T in Proposition 5.23.

≥ 5 for $k = 0$). As the tree in Figure 19(b) with root r is not α -optimal for $\alpha > 1/2$, cf. (R10), we conclude from Proposition 4.15, Lemma 5.5 and Lemma 5.9 that this tree does not occur as a subtree of an optimal tree. Thus T has no vertex of degree ≥ 5 , i.e., T fulfils LC1–LC5.

FIGURE 20. Shape of T in Proposition 5.23.

So by Lemma 5.20, every vertex of T of type B is adjacent to 2 or 3 leaves and has degree 3 or 4. We conclude that $T = T_5^*$ or it is a caterpillar tree of the shape given in Figure 20 for some $k \geq 0$ and some $\ell \in \{2, 3\}$. We note that the tree in Figure 21 with root r is not α -optimal for $\alpha > 2/17$,

FIGURE 21. Subtree of T in Proposition 5.23.

cf. (R10), thus this tree does not occur as a rooted subtree of an optimal tree by Proposition 4.15 and Lemma 5.5. This implies that $k \leq 2$ or $(k, \ell) = (3, 2)$. For $(k, \ell) = (2, 3)$, the resulting tree is not optimal, cf. (R3). The remaining cases correspond to $T \in \{T_8^*, T_9^*, T_{12}^*, T_{13}^*, T_{16}^*, T_{20}^*\}$. \square

We are now able to prove Theorem 5.2.

Proof of Theorem 5.2. As $T \notin \mathcal{S}$, T has no light vertex by Proposition 5.18 and fulfils LC1–LC4. By Proposition 5.23, T contains no 3-claw as a rooted subtree, so T fulfils LC1–LC4 and LC6. By Lemmata 5.3, 5.4, 5.9, 5.12 and LC6, T contains a 2-claw and fulfils LC5 by Lemma 5.19. \square

We conclude this section with refined bounds on ρ for subtrees of type A of optimal trees. The bounds only depend on the LC.

Lemma 5.24. *Let T be a tree fulfilling the LC and let A be a rooted subtree of T of order > 1 and type A . Then*

$$\frac{2}{3} \leq \rho(A) < \sqrt{3} - 1 \leq 0.7321.$$

If no branch of the unique branch of A is a leaf, then

$$\rho(A) < 0.688.$$

Proof. We prove the result by induction on the order of A . By the LC, we have $A = \mathcal{AB}(T_1, \dots, T_r)$ for some $r \in \{2, 3\}$ and rooted trees T_1, \dots, T_r . If $r = 2$, then both T_1 and T_2 are leaves by the LC and $A = F$ with $\rho(F) = 2/3$.

We now consider the case $r = 3$. By the LC, there are at most two leaves among T_1, T_2, T_3 . Thus $2 \leq \rho(T_1) + \rho(T_2) + \rho(T_3) < 2 + (\sqrt{3} - 1)$ by the induction hypothesis. We obtain

$$\frac{2}{3} = \frac{1}{1 + \frac{1}{2}} \leq \rho(A) = \frac{1}{1 + \frac{1}{\rho(T_1) + \rho(T_2) + \rho(T_3)}} < \frac{1}{1 + \frac{1}{1 + \sqrt{3}}} = \frac{1 + \sqrt{3}}{2 + \sqrt{3}} = \sqrt{3} - 1.$$

If none of T_1, T_2, T_3 is a leaf, we use the upper bound $\rho(T_1) + \rho(T_2) + \rho(T_3) < 3(\sqrt{3} - 1)$ to obtain

$$\rho(A) = \frac{1}{1 + \frac{1}{\rho(T_1) + \rho(T_2) + \rho(T_3)}} < \frac{1}{1 + \frac{1}{3(\sqrt{3} - 1)}} = \frac{21 - 3\sqrt{3}}{23} < 0.688.$$

\square

If there is a vertex of type B and degree 4 which is adjacent to two leaves (e.g., in a CL) in an optimal tree, this has consequences to every vertex of type B , as the following lemma shows.

Lemma 5.25. *Let $T \notin \mathcal{S}$ be an optimal tree. If there is a vertex v of degree 4 of T which is adjacent to two leaves, then every vertex w of T of type B is adjacent to at least one leaf.*

Proof. We assume the contrary and denote the rooted connected components of $T - w$ by S_0, S_1, S_2, S_3 where v is contained in S_0 and the rooted connected components of $T - v$ by T_0, T_1, L, L with w contained in T_0 . As $1 = \rho(L) > \rho(S_3)$, Lemma 5.8 and Lemma 4.21 (3) yield

$$\frac{5}{3} \leq 1 + \rho(T_1) \leq \rho(S_1) + \rho(S_2) + 0.1153 < 2(\sqrt{3} - 1) + 0.1153 < 1.58,$$

a contradiction. □

6. THE UPPER BOUND: GLOBAL STRUCTURE

6.1. Outline Graph. Now we start with the discussion of the global structure of optimal trees. Let us first collect a few results on the outline graph of an optimal tree.

Lemma 6.1. *Let $T \notin \mathcal{S}$ be an optimal tree of order n and T' its outline graph as defined in Definition 3.2. Then T' has the following properties.*

- (1) *The leaves of T' correspond to rooted subtrees of type A of T , the non-leaves of T' correspond to vertices of type B of T .*
- (2) *If there is a vertex of degree 3 in T' , then $n \equiv 0 \pmod{7}$, T has the shape as given in Figure 4(e) and*

$$k = \frac{n-7}{7}.$$

- (3) *There is no vertex v in T' which is adjacent to an L and an F .*
- (4) *If T' is of order 1, then $n \equiv 1 \pmod{7}$ and $T = C^{(n-1)/7}L$ or $n \equiv 4 \pmod{7}$ and $T = C^{(n-4)/7}F$.*

Proof. (1) By construction, all special leaves of T' correspond to rooted subtrees of type A of T . A leaf in T is either contained in some larger special leaf or is eventually seen as an L in T' . All non-leaves of T of type A are either contained in some larger special edge or special leaf or they are transformed into a C_*^0 . Thus all non-leaves of T' have to correspond to vertices of type B of T .

- (2) We denote the vertex of degree 3 by v . By Theorem 5.2, two of the neighbours of v are leaves. Thus we have one of the situations in Figure 22 for appropriate $k \geq 0$ and rooted

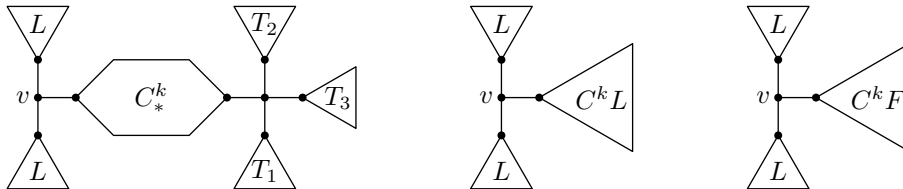

FIGURE 22. Possible Cases in Lemma 6.1.

trees T_1, T_2, T_3 . The first case is a contradiction to the construction of the outline, as a subtree $C^k F$ would have been contracted earlier than the C_*^k . The second case is also not a correct outline, as this graph is isomorphic to a $C^k F$ (use the L in the present $C^k L$ as the new root).

So we are left with the third case. In this case, we have $n = |T| = 3 + 7k + 4$, which immediately implies $n \equiv 0 \pmod{7}$ and $k = (n - 7)/7$. And this is exactly the situation in Figure 4(e).

- (3) We assume that there is a vertex v in T' which is adjacent to an L and an F . This could mean one of the situations in Figure 23, where $S_j \in \{L, F\}$ for $j \in \{0, 1, 2\}$.
 - (a) In the situation in Figure 23(a), a $C_*^{k_1+k_2+1}$ would have been used in the outline of T instead of $v, L, F, C_*^{k_1}$ and $C_*^{k_2}$.
 - (b) In the situation in Figure 23(b), a $C^{k_1+k_2+1}S_0$ would have been used in the outline of T instead of $v, L, F, C_*^{k_1}$ and $C^{k_2}S_0$.

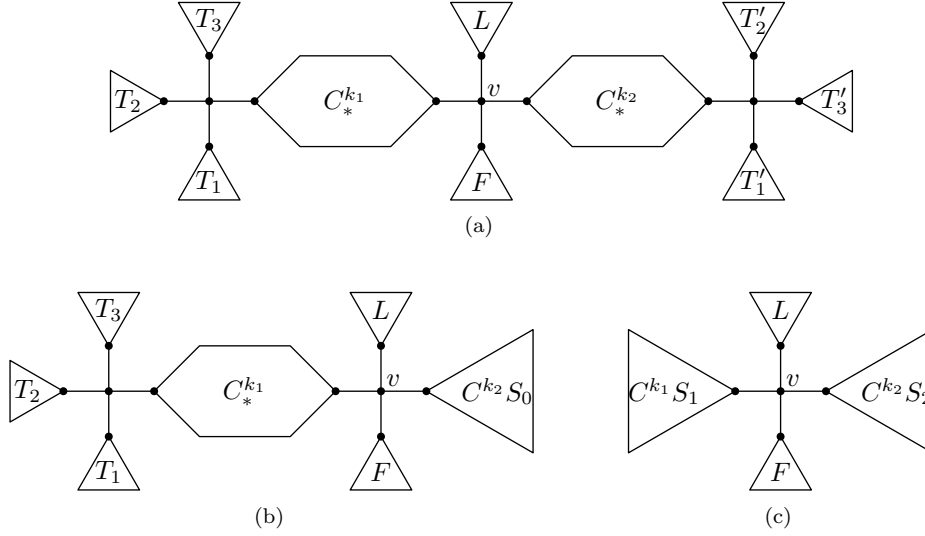

FIGURE 23. Possible cases in Lemma 6.1

(c) We consider the situation in Figure 23(c).

If $S_1 = S_2 = F$, the graph is isomorphic to the graph in Figure 4(e), i.e., a $C^{k_1+k_2+1}F$ would have been combined with a vertex of degree 3 and two leaves in the outline of T .

If $S_1 = L$, the graph is isomorphic to $C^{k_1+k_2+1}S_2$, and this would have been taken in the outline of T .

(4) If T' is of order 1, then the unique vertex of T' must be a $C^k F$ or a $C^k L$ for a suitable k . In the first case, we have $n = 7k + 4$, in the second $n = 7k + 1$.

□

6.2. Chains. In the global structure of optimal trees, chains as introduced in Definition 3.1 occur prominently. This subsection is devoted to the computation of the relevant parameters and to some further necessary optimality criteria in relation to chains. Recall that the growth constant $\lambda \approx 10.1097722286464$ in Theorem 1.2 is defined as the larger root of the polynomial $x^2 - 11x + 9$. In the following, the other root of this polynomial is denoted by $\bar{\lambda} \approx 0.890227771353556$.

Lemma 6.2. (1) *Let T be a rooted tree of type A. Then*

$$\begin{pmatrix} m(CT) \\ m_0(CT) \end{pmatrix} = M \begin{pmatrix} m(T) \\ m_0(T) \end{pmatrix}, \quad \rho(CT) = \sigma(\rho(T)),$$

with

$$M = \begin{pmatrix} 8 & 3 \\ 5 & 3 \end{pmatrix}, \quad \sigma : \mathbb{R}^+ \rightarrow \mathbb{R}^+; x \mapsto 1 - \frac{3}{8 + 3x}.$$

(2) *We have*

$$\begin{aligned} m(C^k L) &= G_{k+1}, & m_0(C^k L) &= G_{k+1} - 3G_k, \\ m(C^k F) &= 3G_{k+1} - 3G_k, & m_0(C^k F) &= 2G_{k+1} - G_k, \end{aligned} \quad \text{with} \quad G_k = \frac{\lambda^k - \bar{\lambda}^k}{\lambda - \bar{\lambda}}.$$

(3) *Let $\rho_{lim} = (\lambda - 8)/3 \approx 0.7032574$ and $x > 0$. If $x < \rho_{lim}$, then the sequence $\sigma^k(x)$ is strictly increasing, if $x > \rho_{lim}$, then the sequence $\sigma^k(x)$ is strictly decreasing. In both cases, $\lim_{k \rightarrow \infty} \sigma^k(x) = \rho_{lim}$.*

In particular, $\rho(C^k F)$ is strictly increasing and $\rho(C^k L)$ is strictly decreasing.

Proof. (1) This is a straightforward consequence of the recursive formulæ (4.4) and (4.5) for m , m_0 and ρ .

- (2) The eigenvalues of M are λ and $\bar{\lambda}$. Thus the sequences $m(C^k L)$, $m_0(C^k F)$, $m(C^k F)$, $m_0(C^k F)$ for $k \geq 0$ are elements of the linear space spanned by λ^k and $\bar{\lambda}^k$. Another basis of this linear space is given by G_{k+1} and G_k . It therefore suffices to check the formulæ for $k = 0$ and $k = 1$.
- (3) It is easily checked that ρ_{lim} is the unique positive fixed point of σ . The assertions on $\sigma^k(x)$ are easy consequences of the definition of σ . Finally, the assertions on $\rho(C^k F)$ and $\rho(C^k L)$ follow from $\rho(F) = 2/3$ and $\rho(L) = 1$.

□

Next we show that an L and a $C^k F$ never occur as neighbours of the same vertex in the outline of an optimal tree.

Lemma 6.3. *Let $T \notin \mathcal{S}$ be an optimal tree, v a vertex of degree 4 and T_1, T_2, T_3, T_4 the rooted connected components of $T - v$. We assume that $T_1 = L$ and $T_2 = C^k F$ for some $k \geq 0$. Then $F \in \{T_2, T_3, T_4\}$. In particular, v is not in the outline of T .*

Proof. We assume $k > 0$. Without loss of generality, we also assume that $\rho(T_3) \leq \rho(T_4)$. The tree T has the shape shown in Figure 24(a). If $\rho(T_3) > \rho(F) = 2/3$, we have $\rho(L) + \rho(T_4) \leq \rho(L) + \rho(F)$ by Lemma 4.21 (2), which implies that $\rho(T_4) = 2/3$ and $\rho(T_3) = 2/3$ by Lemma 5.24, contradiction.

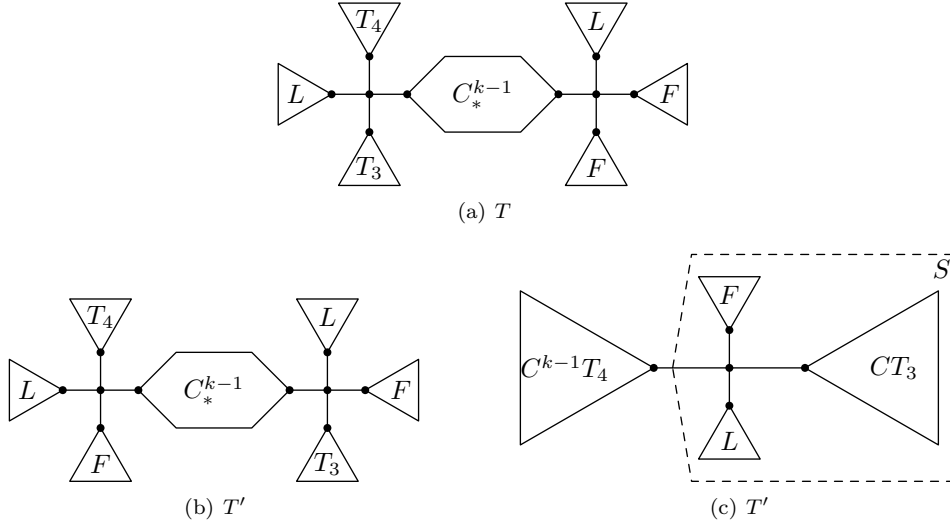

FIGURE 24. Trees T and T' considered in Lemma 6.3.

Therefore, we have $\rho(T_3) = 2/3$, thus $T_3 \in \{F, A_{14}^*, A_{24}^*\}$ by Lemma 5.16. In the case $T_3 = F$, Lemma 6.1 yields the result. Thus we are left with $T_3 \in \{A_{14}^*, A_{24}^*\}$.

We consider the tree T' where F and T_3 have been exchanged, cf. Figure 24(b). From Lemma 4.18 we conclude that $m(T') = m(T)$, i.e., T' is also an optimal tree. We rewrite T' as in Figure 24(c). For $T_3 \in \{A_{14}^*, A_{24}^*\}$, the rooted tree S is not α -optimal for any $\alpha > 1/3$, cf. (R11). As $\rho(C^{k-1}T_4) \geq 2/3$ by Lemma 5.24, this is a contradiction to Proposition 4.15 and the optimality of T' . □

We now prove a necessary optimality condition involving one chain element.

Lemma 6.4. *Let $T \notin \mathcal{S}$ be an optimal tree, v a vertex of type B and degree 4 of T and CS_1, S_2, S_3, S_4 the rooted connected components of $T - v$ for some rooted trees S_1, S_2, S_3, S_4 .*

- (1) *If neither S_3 nor S_4 is a leaf, then*

$$\rho(S_1) \leq \rho(S_2).$$

(2) If S_3 is a leaf and $\rho(S_4) > 2/3$, then

$$\rho(S_1) \geq \rho(S_2).$$

Proof. If $\rho(S_1) > \rho(S_2)$, then $5/3 = \rho(L) + \rho(F) \leq \rho(S_3) + \rho(S_4)$ by Lemma 4.21 (2), i.e., S_3 or S_4 is a leaf by Lemma 5.24.

If $\rho(S_1) < \rho(S_2)$, then $5/3 \geq \rho(S_3) + \rho(S_4)$ by Lemma 4.21 (2), i.e., either both S_3 and S_4 are non-leaves or S_3 , say, is a leaf and $\rho(S_4) \leq 2/3$.

The contrapositions are the statements of the lemma. \square

The following lemma lists some consequences of this result.

Lemma 6.5. *Let $T \notin \mathcal{S}$ be an optimal tree, v a vertex of degree 4 and T_0, T_1, T_2, T_3 the rooted connected components of $T - v$.*

(1) *Let $\ell \leq 4$ and let $T_j = C^{k_j} S_j$ for some $k_j \geq 0$ and some rooted tree S_j with $\rho(S_j) < 7/10$ for $j \in \{0, \dots, \ell - 1\}$. Further assume that T_j is not a leaf for $j \in \{\ell, \dots, 3\}$ and that $k_0 \leq \dots \leq k_{\ell-1}$.*

Then $k_{\ell-1} \leq k_0 + 1$ and, if $k_j < k_{j+1}$ for some $0 \leq j < \ell - 1$, then $\rho(S_j) \geq \rho(S_{j+1})$.

(2) *If $T_0 = L$, $T_1 = C^{k_1} S_1$, $T_2 = C^{k_2} S_2$ with $k_1, k_2 \geq 0$, $\rho(C^{\ell_j+1} L) < \rho(S_j) \leq \rho(C^{\ell_j} L)$ with $\ell_j \in \{0, 1\}$ for $j \in \{1, 2\}$ and finally $\rho(T_3) > 2/3$, then we have $k_2 + \ell_2 \leq k_1 + \ell_1 + 1$.*

Furthermore, if $\sigma^{-\ell_1}(\rho(S_1)) > \sigma^{-\ell_2}(\rho(S_2))$, then $k_2 \leq \max\{0, k_1 + \ell_1 - \ell_2\}$.

Proof. (1) Assume that $k_{\ell-1} > k_0 + 1$. Then

$$\rho(C^{k_{\ell-1}-1} F) \leq \rho(C^{k_{\ell-1}-1} S_{\ell-1}) \leq \rho(C^{k_0} S_0) < \rho(C^{k_0+1} F)$$

by the monotonicity of σ , Lemma 5.24, Lemma 6.4 and the fact that $\sigma(2/3) = 7/10$. We conclude that $k_{\ell-1} - 1 < k_0 + 1$, i.e., $k_{\ell-1} \leq k_0 + 1$, contradiction. Thus $k_{\ell-1} \leq k_0 + 1$.

If $k_j < k_{j+1}$, then $k_{j+1} = k_j + 1$. From Lemma 6.4 we see that

$$\rho(C^{k_j} S_{j+1}) = \rho(C^{k_{j+1}-1} S_{j+1}) \leq \rho(C^{k_j} S_j),$$

which yields $\rho(S_{j+1}) \leq \rho(S_j)$ in view of the monotonicity of σ .

(2) Assume that $k_2 > 0$. By Lemma 6.4, we have

$$\rho(C^{k_2+\ell_2-1} L) \geq \rho(C^{k_2-1} S_2) \geq \rho(C^{k_1} S_1) > \rho(C^{k_1+\ell_1+1} L),$$

which yields $k_2 + \ell_2 - 1 < k_1 + \ell_1 + 1$ by Lemma 6.2 and therefore $k_2 + \ell_2 \leq k_1 + \ell_1 + 1$. If $k_2 = 0$, then the same inequality holds trivially as ℓ_2 has been assumed to be at most 1.

Now we turn to the second assertion and assume $k_2 > 0$ and $\sigma^{-\ell_1}(\rho(S_1)) > \sigma^{-\ell_2}(\rho(S_2))$.

We have

$$\sigma^{k_2-1}(\rho(S_2)) = \rho(C^{k_2-1} S_2) \geq \rho(C^{k_1} S_1) = \sigma^{k_1+\ell_1}(\sigma^{-\ell_1}(\rho(S_1))) > \sigma^{k_1+\ell_1-\ell_2}(\rho(S_2))$$

by Lemma 6.4, which yields $k_2 - 1 < k_1 + \ell_1 - \ell_2$, i.e., $k_2 \leq k_1 + \ell_1 - \ell_2$, as required. For $k_2 = 0$, there is nothing to show. \square

6.3. Switching Forks and Leaves. So far, we mainly compared optimal trees to trees where some subtrees have been switched between two positions. It turns out that more invasive operations are needed in order to obtain information on the global structure of optimal trees.

The basic idea is the following: If 7 forks are replaced by 7 leaves, the order of the tree is reduced by $7 \cdot 3 = 21$. As a chain element requires 7 vertices, these 21 “free” vertices can be used to introduce 3 chain elements. If all this is done at the “right” positions, then $m(T)$ increases. In some circumstances, however, the inverse operation may be beneficial.

Before we state the main lemma regarding such exchange operations, we collect two technical details concerning the floor function in the following lemma.

Lemma 6.6. (1) For real x and positive integers d , the identity

$$\lfloor dx \rfloor = \sum_{j=0}^{d-1} \left\lfloor x + \frac{j}{d} \right\rfloor$$

holds.

(2) Let $d \geq 0$ and k_0, \dots, k_{d-1} be integers with

$$k_0 \leq k_1 \leq \dots \leq k_{d-1} \leq k_0 + 1.$$

Then

$$k_j = \left\lfloor \frac{k+j}{d} \right\rfloor \quad \text{with} \quad k = k_0 + k_1 + \dots + k_{d-1}$$

for $j \in \{0, \dots, d-1\}$.

Proof. (1) Cf. Graham, Knuth and Patashnik [6, (3.26)].

(2) Choose $1 \leq r \leq d$ such that $k_0 = \dots = k_{r-1} < k_r \leq \dots \leq k_{d-1} = k_0 + 1$. Then $k = dk_0 + (d-r)$ and

$$\left\lfloor \frac{k+j}{d} \right\rfloor = \left\lfloor k_0 + \frac{d+j-r}{d} \right\rfloor = k_0 + [d+j-r \geq d] = k_0 + [j \geq r] = k_j$$

for $j \in \{0, \dots, d-1\}$. □

Now we are able to provide the required exchange operations. Their consequences will be exploited afterwards. The proof relies on similar ideas as the proof of Lemma 5.22.

Lemma 6.7. Let T be a tree fulfilling the LC and let T' be a tree that is obtained from T by replacing one rooted subtree S by S' , where S and S' will be specified below.

- (1) If $S = \mathcal{B}(C^{k_0}F, C^{k_1}F, C^{k_2}F)$ with $k_j = \lfloor (k+j)/3 \rfloor$ for some $k \geq 0$ and $S' = \mathcal{B}(C^{\lfloor k/2 \rfloor + 1}L, C^{\lfloor (k+1)/2 \rfloor + 1}L, L)$, then $m(T')/m(T) \geq 5.211$ and $|T'| - |T| = 5$.
- (2) If $S = \mathcal{B}(C^{k_0}F, C^{k_1}F, C^{k_2}F)$ with $k_j = \lfloor (k+j)/3 \rfloor$ for some $k \geq 0$ and $S' = \mathcal{B}(C^{\lfloor k/2 \rfloor + 1}L, C^{\lfloor (k+1)/2 \rfloor}L, L)$, then $m(T')/m(T) \geq 0.5154$ and $|T'| - |T| = -2$.
- (3) If $S = \mathcal{B}(C^{k_0}F, C^{k_1}F, C^{k_2}F)$ with $k_j = \lfloor (k+j)/3 \rfloor$ for some $k \geq 0$ and $S' = \mathcal{B}(C^kF, F, L)$, then $m(T')/m(T) \geq 0.3726$ and $|T'| - |T| = -3$.
- (4) If

$$S = \mathcal{B}(C^{k+\lfloor (j+1)/3 \rfloor}F, C^{k+\lfloor (j+2)/3 \rfloor}F, C^k \mathcal{AB}(C^{k+\lfloor (i+1)/4 \rfloor}F, C^{k+\lfloor (i+2)/4 \rfloor}F, C^{k+\lfloor (i+3)/4 \rfloor}F))$$

and $S' = \mathcal{B}(L, F, C^{2k+i+j} \mathcal{AB}(C^{2k+1}L, C^{2k+1}L, L))$ for some $k \geq 0$, $i \in \{0, 1, 2, 3\}$, $j \in \{0, 1, 2\}$, then $m(T')/m(T) \geq 1.943$ and $|T'| - |T| = 2$.

- (5) If $S = \mathcal{B}(L, C^{\lfloor k/2 \rfloor}L, C^{\lfloor (k+1)/2 \rfloor}L)$ and $S' = \mathcal{B}(L, F, C^{k-1}F)$ for some $k \geq 1$, then $m(T')/m(T) \geq 0.722$ and $|T'| - |T| = -1$.
- (6) If $S = \mathcal{B}(L, C^{\lfloor k/2 \rfloor}L, C^{\lfloor (k+1)/2 \rfloor}L)$ and $S' = \mathcal{B}(C^{\lfloor (k-1)/3 \rfloor}F, C^{\lfloor k/3 \rfloor}F, C^{\lfloor (k+1)/3 \rfloor}F)$ for some $k \geq 1$, then $m(T')/m(T) \geq 27/14$ and $|T'| - |T| = 2$. If $k \geq 2$, then $m(T')/m(T) \geq 1.9302$.
- (7) If $S = \mathcal{B}(C^{k+1+t}L, L, C^k \mathcal{AB}(C^{k+1+\lfloor (s+1)/3 \rfloor}L, C^{k+1+\lfloor (s+2)/3 \rfloor}L, L))$ and $S' = \mathcal{B}(F, L, C^{k-1+\lfloor (s+t+2)/4 \rfloor} \mathcal{AB}(C^{k+\lfloor (s+t+3)/4 \rfloor}F, C^{k+\lfloor (s+t+4)/4 \rfloor}F, C^{k+\lfloor (s+t+5)/4 \rfloor}F))$ for some $k \geq 1$, $s \in \{0, 1, 2\}$, $t \in \{0, 1\}$, then $m(T')/m(T) \geq 0.5181$ and $|T'| - |T| = -2$.
- (8) If

$$S = \mathcal{B}(C^tL, L, \mathcal{AB}(C^{\lfloor s/2 \rfloor}L, C^{\lfloor (s+1)/2 \rfloor}L, L))$$

and $S' = \mathcal{B}(C^{\lfloor (s+t-1)/3 \rfloor}F, C^{\lfloor (s+t)/3 \rfloor}F, C^{\lfloor (s+t+1)/3 \rfloor}F)$ for some $s \in \{1, 2, 3, 4\}$ and $t \in \{0, 1, 2\}$, then $m(T')/m(T) \geq 0.516$ and $|T'| - |T| = -2$.

- (9) If $S = \mathcal{B}(C^tL, L, \mathcal{AB}(C^{\lfloor s/2 \rfloor}L, C^{\lfloor (s+1)/2 \rfloor}L, L))$ and $S' = \mathcal{B}(L, F, C^{s+t}F)$ for some $s \in \{1, 2, 3, 4\}$ and $t \in \{0, 1, 2\}$, then $m(T')/m(T) \geq 1.95$ and $|T'| - |T| = 2$.

Proof. (1) Let T consist of some rooted subtree T_1 , S and the edge between the roots of T_1 and S . Then from Lemma 4.4 we obtain

$$\begin{aligned} \frac{m(T')}{m(T)} &= \frac{m_0(S')}{m_0(S)} \cdot \frac{\rho(T_1) + \rho(C^{\lfloor k/2 \rfloor + 1}L) + \rho(C^{\lfloor (k+1)/2 \rfloor + 1}L) + 1}{\rho(T_1) + \rho(C^{k_0}F) + \rho(C^{k_1}F) + \rho(C^{k_2}F)} \\ &= \frac{m_0(S')}{m_0(S)} \left(1 + \frac{\rho(C^{\lfloor k/2 \rfloor + 1}L) + \rho(C^{\lfloor (k+1)/2 \rfloor + 1}L) + 1 - \rho(C^{k_0}F) - \rho(C^{k_1}F) - \rho(C^{k_2}F)}{\rho(T_1) + \rho(C^{k_0}F) + \rho(C^{k_1}F) + \rho(C^{k_2}F)} \right) \\ &\geq \frac{m_0(S')}{m_0(S)} \left(1 + \frac{\rho(C^{\lfloor k/2 \rfloor + 1}L) + \rho(C^{\lfloor (k+1)/2 \rfloor + 1}L) + 1 - \rho(C^{k_0}F) - \rho(C^{k_1}F) - \rho(C^{k_2}F)}{\sqrt{3} - 1 + \rho(C^{k_0}F) + \rho(C^{k_1}F) + \rho(C^{k_2}F)} \right) \end{aligned}$$

where

$$\rho(C^{\lfloor k/2 \rfloor + 1}L) + \rho(C^{\lfloor (k+1)/2 \rfloor + 1}L) + 1 > 3\rho_{lim} > \rho(C^{k_0}F) + \rho(C^{k_1}F) + \rho(C^{k_2}F),$$

cf. Lemma 6.2, and Lemma 5.24 have been used. From Lemma 6.2 and Lemma 6.6, we get

$$\begin{aligned} \frac{m(T')}{m(T)} &\geq \frac{\lambda^4(\lambda - \bar{\lambda})}{(3\lambda - 3)^3} (1 + O(q^{k/3})) \frac{\sqrt{3} - 1 + 2\rho_{lim}(1 + O(q^{k/2})) + 1}{\sqrt{3} - 1 + 3\rho_{lim}(1 + O(q^{k/3}))} \\ &\geq 5.21101232 \end{aligned}$$

with $q = \bar{\lambda}/\lambda \approx 0.088$, where we replaced the explicit formulæ obtained from Lemma 6.2 by asymptotic expansions for ease of presentation; the actual computations leading to the given constant have been performed exactly—in this particular case, it even turned out that the whole expression was strictly decreasing in k . The explicit branch L of S' has been taken into account exactly instead of using Lemma 6.2.

We have $|S| = 1 + 7(k_0 + k_1 + k_2) + 3 \cdot 4 = 13 + 7k$ and $|S'| = 1 + 7(2 + \lfloor k/2 \rfloor + \lfloor (k+1)/2 \rfloor) + 3 = 18 + 7k$ by Lemma 6.6.

- (2) Analogous.
- (3) Analogous.
- (4) Analogous.
- (5) Analogous, but the lower bound $\rho(T_1) \geq 2/3$ (Lemma 5.24) has to be used, as $\rho(L) + \rho(F) + \rho(C^{k-1}F) < 1 + 2\rho_{lim} < \rho(L) + \rho(C^{\lfloor k/2 \rfloor}L) + \rho(C^{\lfloor (k+1)/2 \rfloor}L)$.
- (6) Analogous.
- (7) Analogous.
- (8) Analogous, but simpler, as this is a finite case and no limits have to be considered.
- (9) Analogous.

□

Remark 6.8. The precise proof of Lemma 6.7 has been carried out using Sage [20]. The program is available in [11].

6.4. CL -free Optimal Trees. Throughout this subsection, we assume that $T \notin \mathcal{S}$ is an optimal tree which is CL -free, i.e., it does not contain a CL as a rooted subtree. Obviously, such a tree does not contain any C^kL as rooted subtree for $k \geq 1$. We will describe all optimal trees with this property.

Lemma 6.9. *Let $T \notin \mathcal{S}$ be a CL -free optimal tree and v be a vertex of degree 4 in the outline graph of T which is adjacent to at least three “special leaves” T_0, T_1, T_2 with $|T_0| \leq |T_1| \leq |T_2|$. Then there is a $k \geq 0$ such that $T_j = C^{k_j}F$ with $k_j = \lfloor (k+j)/3 \rfloor$ for $j \in \{0, 1, 2\}$.*

Proof. As T is CL -free, $T_j \neq C^{k_j}L$ for any $k_j > 0$ and $j \in \{0, 1, 2\}$. So for every j we have $T_j = L$ or $T_j = C^{k_j}F$ for some k_j . As T is optimal, the case $T_0 = T_1 = T_2 = L$ is excluded by LC6. The cases $T_0 = T_1 = L, T_2 = C^{k_2}F$ and $T_0 = L, T_1 = C^{k_1}F, T_2 = C^{k_2}F$ are excluded by Lemma 6.3. Thus $T_j = C^{k_j}F$ for some $k_j \geq 0$ for all j . As v is in the outline of T , it is not adjacent to a leaf by Lemma 6.3. Thus Lemma 6.5 (1) (with $\ell = 3$) and Lemma 6.6 prove the assertion. □

Lemma 6.10. *Let $T \notin \mathcal{S}$ be a CL -free optimal tree. Then there are no three distinct vertices in the outline of T such that each of them is adjacent to three “special leaves”.*

Proof. Assume that there are three distinct vertices v_0, v_1, v_2 in the outline of T such that v_i is adjacent to $C^{k_{i0}}F, C^{k_{i1}}F, C^{k_{i2}}F$ with $k_{ij} = \lfloor (k_i + j)/3 \rfloor$ for some $k_i \geq 0$ and $j \in \{0, 1, 2\}$. By Lemma 6.9 this is the only case to consider.

Replacing the rooted subtree with root v_0 and branches $C^{k_{00}}F, C^{k_{01}}F, C^{k_{02}}F$ by a rooted subtree with root v_0 and branches $C^{\lfloor k_0/2 \rfloor + 1}L, C^{\lfloor (k_0+1)/2 \rfloor + 1}L, L$, cf. Lemma 6.7 (1), yields a tree T' which is not necessarily optimal, but fulfils the LC.

Replacing the rooted subtree with root v_1 and branches $C^{k_{10}}F, C^{k_{11}}F, C^{k_{12}}F$ in T' by a rooted subtree with root v_1 and branches $C^{\lfloor k_1/2 \rfloor + 1}L, C^{\lfloor (k_1+1)/2 \rfloor}L, L$, cf. Lemma 6.7 (2), yields a tree T'' , which still fulfils the LC.

Replacing the rooted subtree with root v_2 and branches $C^{k_{20}}F, C^{k_{21}}F, C^{k_{22}}F$ in T'' by a rooted subtree with root v_2 and branches $C^{k_2}F, F, L$, cf. Lemma 6.7 (3), yields a tree T''' .

Lemma 6.7 (1, 2 and 3) yields $|T'''| - |T| = 5 - 2 - 3 = 0$ and

$$\frac{m(T''')}{m(T)} = \frac{m(T''')}{m(T'')} \cdot \frac{m(T'')}{m(T')} \cdot \frac{m(T')}{m(T)} \geq 5.211 \cdot 0.5154 \cdot 0.3726 > 1.0007,$$

thus $m(T''') > m(T)$, contradiction to the optimality of T . \square

Lemma 6.11. *Let $T \notin \mathcal{S}$ be a CL-free optimal tree of order n and u, v two distinct vertices of degree 4 in the outline graph of T which are adjacent to three special leaves.*

Then $n \equiv 6 \pmod{7}$ and T is of the shape given in Figure 4(d) where

$$k_j = \left\lfloor \frac{n - 27 + 7j}{49} \right\rfloor$$

for $0 \leq j \leq 6$ or $(k_0, k_1, k_2, k_3, k_4, k_5, k_6) = (1, 0, 0, 0, 0, 0, 0)$.

Proof. By Lemma 6.1, the outline of T does not contain a vertex of degree 3. By Lemma 6.10, the outline graph of T is a caterpillar tree. By Lemma 6.9, it must be of the shape shown in Figure 25 for some $s \geq 0$, some non-negative integers k_0, \dots, k_8 and some special leaves T_j, T'_j for $j \in \{1, \dots, s\}$. As T is CL-free, T_j is a leaf or a $C^{\ell_j}F$ and T'_j is a leaf or a $C^{\ell'_j}F$ for suitable $\ell_j, \ell'_j \geq 0$ and $j \in \{1, \dots, s\}$.

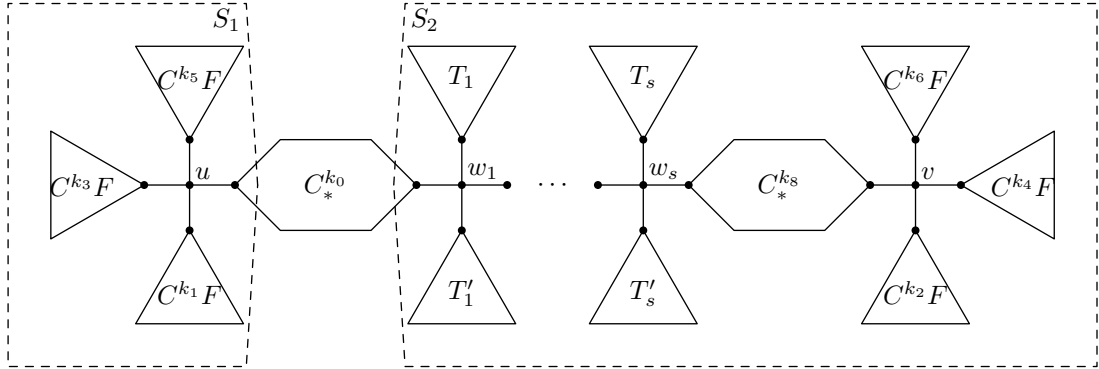

FIGURE 25. Decomposition of T for Lemma 6.11.

Assume that $s > 0$. By Lemma 5.25, it is impossible that both $T_1 = L$ and $T'_1 = L$, as u is not adjacent to a leaf. By Lemma 6.3 we conclude that $T_1 = C^{\ell_1}F$ and $T'_1 = C^{\ell'_1}F$ for some $\ell_1 \geq 0, \ell'_1 \geq 0$. Lemma 5.24 implies that $\rho(S_1) \leq 0.688$ and $\rho(S_2) \leq 0.688$.

W.l.o.g. we assume $k_1 \leq k_3 \leq k_5$. We claim that

$$k_0 \leq k_1 \leq k_3 \leq k_5 \leq k_0 + 1. \quad (6.1)$$

If $\rho(S_2) > 2/3 = \rho(F)$ or $k_0 = 0$, this follows from Lemma 6.5 (1). So we consider the case that $\rho(S_2) = 2/3$ and $k_0 > 0$. By Lemma 5.16 and the shape of T as shown in Figure 25, this implies that $S_2 = A_{24}^*$. In particular, we have $T_1 = T'_1 = F$, i.e., $\ell_1 = \ell'_1 = 0$. As $\ell_1 < k_0$, we have $2/3 = \rho(T_1) \geq \rho(S_1)$ and $k_0 \leq 1$ by Lemma 6.5 (1). Thus we have $S_1 = A_{14}^*$ by Lemma 5.16 and

$k_0 = 1$. Then $T = \mathcal{AB}(F, A_{14}^*, A_{24}^*)$ which is not optimal by (R5). This concludes the proof of (6.1).

W.l.o.g we assume $\ell_1 \leq \ell'_1$. If $\rho(S_1) = 2/3$, then $S_1 = A_{14}^*$ and $k_1 = k_3 = k_5 = 0$, thus also $k_0 = 0$ by (6.1). Thus $k_0 \leq \ell_1 \leq \ell'_1 \leq k_0 + 1$ in this case by Lemma 6.5 (1). If $\rho(S_1) > 2/3 = \rho(F)$, we get the same estimate $k_0 \leq \ell_1 \leq \ell'_1 \leq k_0 + 1$ from Lemma 6.5 (1).

Replacing $S = \mathcal{B}(T_1, T'_1, C^{k_0} \mathcal{AB}(C^{k_1} F, C^{k_3} F, C^{k_5} F))$ in T by S' as in Lemma 6.7 (4) yields a tree T' fulfilling the LC.

Replacing $\mathcal{B}(C^{k_2} F, C^{k_4} F, C^{k_6} F)$ in T' as in Lemma 6.7 (2) yields a tree T'' .

By Lemma 6.7 (2 and 4), we have $|T''| = |T|$ and

$$\frac{m(T'')}{m(T)} = \frac{m(T'')}{m(T')} \frac{m(T')}{m(T)} \geq 0.5154 \cdot 1.943 > 1.001,$$

contradiction to the optimality of $m(T)$.

Thus we have shown that $s = 0$, i.e., T is of the shape given in Figure 4(d). We set $k = k_0 + k_1 + k_2 + k_3 + k_4 + k_5 + k_6$ and have $n = 7k + 6 \cdot 4 + 3 = 27 + 7k$ and in particular $n \equiv 6 \pmod{7}$.

We set $a = k_1 + k_3 + k_5$ and $b = k_2 + k_4 + k_6$. Without loss of generality we assume $a \leq b$. By Lemma 6.5 (1) and Lemma 6.6, we have

$$k_1 = \left\lfloor \frac{a}{3} \right\rfloor, \quad k_3 = \left\lfloor \frac{a+1}{3} \right\rfloor, \quad k_5 = \left\lfloor \frac{a+2}{3} \right\rfloor, \quad k_2 = \left\lfloor \frac{b}{3} \right\rfloor, \quad k_4 = \left\lfloor \frac{b+1}{3} \right\rfloor, \quad k_6 = \left\lfloor \frac{b+2}{3} \right\rfloor. \quad (6.2)$$

If $b \geq a + 2$, we obtain $k_6 \geq \lfloor (a+4)/3 \rfloor = k_3 + 1$, thus $\rho(C^{k_6} F) > \rho(C^{k_3} F)$, and Lemma 4.21 (2) and Lemma 6.2 yield

$$\begin{aligned} \rho(C^{k_1} F) + \rho(C^{k_5} F) &< \rho(C^{\lfloor (a+2)/3 \rfloor} F) + \rho(C^{\lfloor (a+3)/3 \rfloor} F) \leq \rho(C^{\lfloor b/3 \rfloor} F) + \rho(C^{\lfloor (b+1)/3 \rfloor} F) \\ &= \rho(C^{k_2} F) + \rho(C^{k_4} F) \leq \rho(C^{k_1} F) + \rho(C^{k_5} F), \end{aligned}$$

a contradiction. We conclude that $a \leq b \leq a + 1$. From (6.2) we immediately conclude that $k_1 \leq k_2 \leq k_3 \leq k_4 \leq k_5 \leq k_6 \leq k_1 + 1$ holds in both cases.

From Lemma 6.5 (1) and Lemma 5.24 we see that $k_0 \leq k_1 + 1$ and $k_6 \leq k_0 + 1$.

If $b = 0$, we therefore obtain

$$(k_0, k_1, k_2, k_3, k_4, k_5, k_6) \in \{(0, 0, 0, 0, 0, 0, 0), (1, 0, 0, 0, 0, 0, 0)\},$$

where we have $T = T_{27}^*$ in the first case and $T = T_{34,2}^*$ in the second case.

If $b > 0$, then $\rho(S_2) > \frac{2}{3} = \rho(F)$ and thus $k_0 \leq k_1$ by Lemma 6.5 (1). Thus we have

$$k_0 \leq k_1 \leq k_2 \leq k_3 \leq k_4 \leq k_5 \leq k_6 \leq k_0 + 1,$$

and therefore $k_j = \lfloor (k+j)/7 \rfloor$ for $j \in \{0, 1, 2, 3, 4, 5, 6\}$ by Lemma 6.6. We have $k \geq 1$, the case $k = 1$ corresponds to $T = T_{34,1}^*$. Indeed, $m(T_{34,1}^*) = m(T_{34,2}^*)$. \square

Proposition 6.12. *Let $T \notin \mathcal{S}$ be a CL-free optimal tree of order $n > 1$. Then $n \equiv 0 \pmod{7}$, $n \equiv 3 \pmod{7}$ or $n \equiv 6 \pmod{7}$ and T has the shape described in Theorem 3.3 for these congruence classes.*

Proof. Let T' be the outline of T . If T' has a vertex of degree 3, Lemma 6.1 yields the required result.

If T' has at least two vertices of degree 4, then there are at least two vertices of degree 4 which are adjacent to at least 3 special leaves. In this case, Lemma 6.11 yields the required result.

We now consider the case that T' has exactly one vertex v of degree 4. Its neighbours are special leaves T_0, T_1, T_2, T_3 , where each T_j is either an L or a $C^{k_j} F$ for $0 \leq j \leq 3$. We assume that $\rho(T_0) \leq \rho(T_1) \leq \rho(T_2) \leq \rho(T_3)$. The case $T_0 = T_1 = T_2 = T_3 = L$ corresponds to $T = T_5^* \in \mathcal{S}$. Then by Lemma 6.3, we cannot have a leaf, so $T_j = C^{k_j} F$ for $0 \leq j \leq 3$. From Lemma 6.5 (1) and Lemma 6.6, we obtain that $k_j = \lfloor (k+j)/4 \rfloor$ for $0 \leq j \leq 3$ and $k = k_0 + k_1 + k_2 + k_3$. We have

$$n = |T| = 1 + 4 \cdot 4 + 7(k_0 + k_1 + k_2 + k_3) = 17 + 7k.$$

We conclude that $n \equiv 3 \pmod{7}$ and obtain

$$k_j = \left\lfloor \frac{n - 17 + 7j}{28} \right\rfloor$$

and of course, T has the shape given in Figure 4(b).

Finally we consider the case that T' has order 1. This case is covered by Lemma 6.1. Both graphs mentioned in this lemma ($C^{(n-1)/7}L$ and $C^{(n-4)/7}F$) contain a CL except for $T = T_1^*$. \square

6.5. Optimal Trees Containing CL . This final subsection is devoted to optimal trees $T \notin \mathcal{S}$ containing a CL as a rooted subtree. By Lemma 5.25, every vertex of type B of such a tree is adjacent to a leaf. By Lemma 6.3, T does not contain any rooted subtree of the shape $C^k F$ for $k > 0$.

Lemma 6.13. *Let $T \notin \mathcal{S}$ be an optimal tree containing CL as a rooted subtree and v a vertex of degree 4 in the outline of T which is adjacent to 3 special leaves T_0, T_1, L with $|T_0| \leq |T_1|$. Then there is a $k \geq 1$ such that $T_j = C^{\lfloor (k+j)/2 \rfloor} L$ for $j \in \{0, 1\}$.*

Proof. Let T_0, T_1, T_2, L denote the rooted connected components of $T - v$. None of them is a $C^k F$ for $k \geq 0$ by Lemma 6.3 and Lemma 5.25. Thus $T_0 = C^{k_0} L$ and $T_1 = C^{k_1} L$ for suitable $k_0, k_1 \geq 0$. As A_{14}^* and A_{24}^* cannot be rooted subtrees of T by Lemma 5.25, we have $\rho(T_2) > 2/3$ by Lemma 5.16. Thus Lemma 6.5 (2) can be used to see that $k_0 \leq k_1 \leq k_0 + 1$. With $k = k_0 + k_1$, Lemma 6.6 and LC6, the desired result follows. \square

Lemma 6.14. *Let $T \notin \mathcal{S}$ be an optimal tree containing CL as a rooted subtree. Then there are no three distinct vertices in the outline of T such that each of them is adjacent to three special leaves.*

Proof. Assume that there are three distinct vertices v_0, v_1, v_2 in the outline of T such that v_i is adjacent to $C^{k_{i0}} L, C^{k_{i1}} L, L$ with $k_{ij} = \lfloor (k_i + j)/2 \rfloor$ for some $k_i \geq 1$ and $j \in \{0, 1\}$. By Lemma 6.13 this is the only case to consider.

Replacing the rooted subtree with root v_0 and branches $C^{k_{00}} L, C^{k_{01}} L, L$ by a rooted subtree with root v_0 and branches $L, F, C^{k_0-1} F$, cf. Lemma 6.7 (5), yields a tree T' , which does not have to be optimal, but fulfils the LC.

Replacing the rooted subtree with root v_1 and branches $C^{k_{10}} L, C^{k_{11}} L, L$ in T' by a rooted subtree with root v_1 and branches $L, F, C^{k_1-1} F$, cf. Lemma 6.7 (5), yields a tree T'' , which still fulfils the LC.

Replacing the rooted subtree with root v_2 and branches $C^{k_{20}} L, C^{k_{21}} L, L$ in T'' by a rooted subtree with root v_2 and branches $C^{\lfloor (k_2-1)/3 \rfloor} F, C^{\lfloor k_2/3 \rfloor} F, C^{\lfloor (k_2+1)/3 \rfloor} F$, cf. Lemma 6.7 (6), yields a tree T''' .

Lemma 6.7 (5 and 6) yields $|T'''| - |T| = -1 - 1 + 2 = 0$ and

$$\frac{m(T''')}{m(T)} = \frac{m(T''')}{m(T'')} \cdot \frac{m(T'')}{m(T')} \cdot \frac{m(T')}{m(T)} \geq 0.722 \cdot 0.722 \cdot \frac{27}{14} > 1.005,$$

thus $m(T''') > m(T)$, contradiction to the optimality of T . \square

Next we need better bounds on the ρ -values of subtrees of type A which are visible in the outline of an optimal tree.

Lemma 6.15. *Let $T \notin \mathcal{S}$ be an optimal tree containing a CL , v be a vertex of degree 4 in the outline of T and L, T_1, T_2, T_3 be the rooted connected components of $T - v$. We assume that $\rho(T_1) \geq \rho(T_2)$ and set $\ell = \lfloor |T_1| > 1 \rfloor$. We further set $S = AB(L, T_1, T_2)$.*

Then

$$\rho(C^{1+\ell} L) < \rho(S) < \rho(C^\ell L).$$

Proof. We prove the lemma by induction on the order of S .

By Lemma 5.24 and LC6, we have $\rho(T_1) + \rho(T_2) \leq 1 - \ell + (1 + \ell)(\sqrt{3} - 1)$.

We write $T_j = C^{k_j} T'_j$ for suitable trees T'_j and maximal $k_j \geq 0$ for $j \in \{1, 2\}$. As the outline of T does not contain a $C^k F$ by Lemma 6.3 and Lemma 5.25, we conclude that either T'_j is a leaf

or we have $\rho(T'_j) > \rho(C^2L)$ by the induction hypothesis. By Lemma 6.2, we have $\rho(T_j) > \rho_{lim}$ in both cases.

We obtain

$$\rho(C^{1+\ell}L) < \frac{1}{1 + \frac{1}{2-\ell+(1+\ell)\rho_{lim}}} \leq \rho(S) = \frac{1}{1 + \frac{1}{1+\rho(T_1)+\rho(T_2)}} \leq \frac{1}{1 + \frac{1}{2-\ell+(1+\ell)(\sqrt{3}-1)}} < \rho(C^\ell L).$$

□

Lemma 6.16. *Let $T \notin \mathcal{S}$ be an optimal tree of order n containing a CL whose outline contains at least two vertices of degree 4. Then $n \equiv 2 \pmod{7}$ and T is of the shape given in Figure 4(a) with*

$$k_0 = \max \left\{ 0, \left\lfloor \frac{n-37}{35} \right\rfloor \right\}, \quad k_j = \begin{cases} \left\lfloor \frac{n-2+7j}{35} \right\rfloor & \text{if } n \geq 37, \\ \left\lfloor \frac{n-9+7j}{35} \right\rfloor & \text{if } n \leq 30 \end{cases}$$

for $j \in \{1, 2, 3, 4\}$.

Proof. By Lemma 6.1, the outline of T has no vertex of degree 3. By Lemma 6.14, the outline graph of T is a caterpillar tree. By Lemma 5.25, Lemma 6.13 and Lemma 6.3, it must be of the shape shown in Figure 26 with $0 \leq k_1 \leq k_3$, $0 \leq k_2 \leq k_4$, $0 \leq k_0$, $0 \leq \ell_1, \dots, 0 \leq \ell_s$, $0 \leq k_5$. By LC6, we have $k_3 > 0$ and $k_4 > 0$.

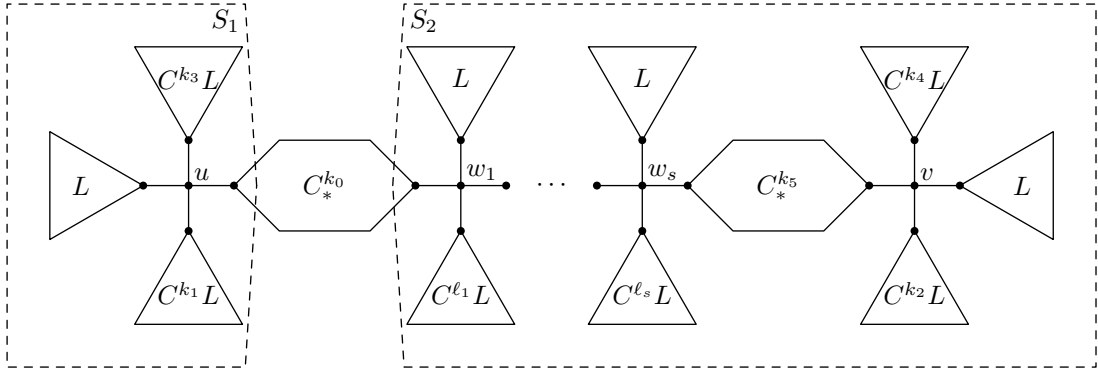

FIGURE 26. Decomposition of T for Lemma 6.16.

We claim that $s = 0$; let us assume, to the contrary, that $s \geq 1$. Then by Lemma 6.15, we have

$$\begin{aligned} \rho(C^{[\ell_1 > 0] + 1}L) &< \rho(S_2) < \rho(C^{[\ell_1 > 0]}L), \\ \rho(C^{[k_1 > 0] + 1}L) &< \rho(S_1) < \rho(C^{[k_1 > 0]}L). \end{aligned}$$

As $\sigma^{-[\ell_1 > 0]}\rho(S_2) < \rho(L)$ and $\sigma^{-[k_1 > 0]}\rho(S_1) < \rho(L)$, Lemma 6.5 (2) and Lemma 6.13 imply

$$\begin{aligned} k_0 &\leq \max\{0, k_1 - [\ell_1 > 0]\}, & k_1 &\leq k_3 \leq k_0 + [\ell_1 > 0] + 1, & k_3 &\leq k_1 + 1, \\ k_0 &\leq \max\{0, \ell_1 - [k_1 > 0]\}, & \ell_1 &\leq k_0 + [k_1 > 0] + 1, \\ & & \text{If } k_0 > 0, & \text{then } k_1 \geq 2 \text{ and } \ell_1 \geq 2 \end{aligned} \tag{6.3}$$

(the last statement following from the two inequalities for k_0) and the analogous inequalities

$$\begin{aligned} k_5 &\leq \max\{0, k_2 - [\ell_s > 0]\}, & k_2 &\leq k_4 \leq k_5 + [\ell_s > 0] + 1, & k_4 &\leq k_2 + 1, \\ k_5 &\leq \max\{0, \ell_s - [k_2 > 0]\}, & \ell_s &\leq k_5 + [k_2 > 0] + 1, \\ & & \text{If } k_5 > 0, & \text{then } k_2 \geq 2 \text{ and } \ell_s \geq 2. \end{aligned} \tag{6.4}$$

Without loss of generality, we may assume $k_5 + k_2 \leq k_0 + k_1$.

We consider 3 cases:

- (1) We assume that $k_0 > 0$ and $k_2 > 0$. From (6.3) and Lemma 6.6, we obtain

$$k_1 = k_0 + 1 + \left\lfloor \frac{s+1}{3} \right\rfloor, \quad k_3 = k_0 + 1 + \left\lfloor \frac{s+2}{3} \right\rfloor, \quad \ell_1 = k_0 + 1 + t$$

for some $s \in \{0, 1, 2\}$ and some $t \in \{0, 1\}$.

We replace $\mathcal{B}(L, C^{\ell_1}L, C^{k_0}\mathcal{AB}(C^{k_1}L, C^{k_3}L, L))$ as in Lemma 6.7 (7) and obtain a tree T' fulfilling the LC.

Replacing $\mathcal{B}(C^{k_2}L, C^{k_4}L, L)$ in T' as in Lemma 6.7 (6), we obtain a tree T'' . We have

$$\frac{m(T'')}{m(T)} \geq 0.5181 \cdot 1.9302 > 1.00003 \quad |T''| = |T|,$$

a contradiction.

- (2) We assume that $k_0 > 0$ and $k_2 = 0$. By (6.4), this implies $k_5 = 0$ and $k_4 = 1$.

We assume first that $s \geq 2$ and replace $\mathcal{B}(L, C^{\ell_1}L, C^{k_0}\mathcal{AB}(C^{k_1}L, C^{k_3}L, L))$ in T as in Lemma 6.7 (7) and obtain a tree T' fulfilling the LC.

We now replace $\mathcal{B}(L, C^{\ell_s}L, \mathcal{AB}(C^{k_2}L, C^{k_4}L, L))$ in T' as in Lemma 6.7 (9) and obtain a tree T'' .

We conclude that

$$\frac{m(T'')}{m(T)} \geq 1.95 \cdot 0.5181 > 1.01, \quad |T''| = |T'|,$$

a contradiction.

Thus we have $s = 1$. By (6.3), we have $2 \leq k_1 \leq k_3$. As $k_4 < k_1$, and thus $\rho(C^{k_4}L) > \rho(C^{k_1}L)$, we obtain

$$2 = \rho(C^{k_2}L) + \rho(L) \leq \rho(C^{k_3}L) + \rho(L) + 0.1153 \leq \rho(C^2L) + \rho(L) + 0.1153 < 2$$

from Lemma 6.2 and Lemma 4.21 (3). This is a contradiction.

- (3) We assume that $k_0 = 0$. By (6.3) this implies $k_1 \leq k_3 \leq 2$ and $\ell_1 \leq 2$. Consequently, we have $k_5 + k_2 \leq k_0 + k_1 \leq 2$, thus $k_5 = 0$, $k_2 \leq k_4 \leq 2$ and $\ell_s \leq 2$ by (6.4).

We assume first that $s \geq 2$ and replace $\mathcal{B}(L, C^{\ell_1}L, \mathcal{AB}(C^{k_1}L, C^{k_3}L, L))$ in T as in Lemma 6.7 (8) and obtain a tree T' .

We now replace $\mathcal{B}(L, C^{\ell_s}L, \mathcal{AB}(C^{k_2}L, C^{k_4}L, L))$ in T' as in Lemma 6.7 (9) and obtain a tree T'' . We conclude that

$$\frac{m(T'')}{m(T)} \geq 1.95 \cdot 0.516 > 1.006, \quad |T''| = |T'|,$$

a contradiction.

Thus we have $s = 1$. It follows that $27 \leq n = 13 + 7(k_1 + k_3 + k_2 + k_4 + \ell_1) \leq 83$. In each of the possible cases remaining, it turns out that $m(T) < m(T_n^*)$ for the tree T_n^* given in Figure 4(d) (or $m(T) < m(T_{34,1}^*) = m(T_{34,2}^*)$ for $n = 34$), contradiction.

So we have shown that $s = 0$ and that T therefore has the shape as in Figure 4(a). We set $k = k_0 + k_1 + k_2 + k_3 + k_4$ and obtain $n = 9 + 7k$ and $n \equiv 2 \pmod{7}$ in particular.

We set $a = k_1 + k_3$ and $b = k_2 + k_4$ and assume that $a \leq b$. From Lemma 6.5 (2) and Lemma 6.6, we see that

$$k_1 = \lfloor a/2 \rfloor, \quad k_3 = \lfloor (a+1)/2 \rfloor, \quad k_2 = \lfloor b/2 \rfloor, \quad k_4 = \lfloor (b+1)/2 \rfloor.$$

If $b \geq a + 2$, we have $k_4 \geq \lfloor (a+3)/2 \rfloor > k_3$ and therefore $k_1 = \lfloor a/2 \rfloor < \lfloor b/2 \rfloor = k_2 \leq k_1$ by Lemma 4.21 (2) and Lemma 6.2, a contradiction. Thus $b \in \{a, a+1\}$ and $k_1 \leq k_2 \leq k_3 \leq k_4 \leq k_1 + 1$ in both cases.

By Lemma 6.15 and Lemma 6.5 (2), we have (in analogy to (6.3) and (6.4))

$$k_0 \leq \max\{0, k_1 - \lfloor k_2 > 0 \rfloor\}, \quad k_4 \leq k_0 + \lfloor k_1 > 0 \rfloor + 1. \quad (6.5)$$

If $k_1 = 0$, we have $k_0 = 0$ and $0 = k_0 \leq k_1 \leq k_2 \leq k_3 \leq k_4 \leq k_0 + 1 = 1$ by (6.5) and $n \leq 30$, i.e., $k_j = \lfloor (n-9+7j)/35 \rfloor$ for $j \in \{0, 1, 2, 3, 4\}$ by Lemma 6.6.

If $k_1 > 0$, we have $n \geq 37$ and (6.5) yields

$$k_0 + 1 \leq k_1 \leq k_2 \leq k_3 \leq k_4 \leq k_0 + 2$$

and therefore $k_j + [j = 0] = \lfloor (k + 1 + j)/5 \rfloor$ for $j \in \{0, 1, 2, 3, 4\}$ by Lemma 6.6. \square

Proposition 6.17. *Let $T \notin \mathcal{S}$ be an optimal tree of order n containing a CL as a rooted subtree. Then $n \equiv 1 \pmod{7}$, $n \equiv 2 \pmod{7}$, $n \equiv 4 \pmod{7}$ or $n \equiv 5 \pmod{7}$ and T has the shape described in Theorem 3.3 for these congruence classes.*

Proof. Let T' be the outline of T . If T' has a vertex of degree 3, Lemma 6.1 shows that T does not contain a CL as a rooted subtree.

If T' has at least two vertices of degree 4, then there are at least two vertices of degree 4 which are adjacent to at least 3 special leaves. In this case, Lemma 6.16 yields the required result.

We now consider the case that T' has exactly one vertex v of degree 4. Its neighbours are special leaves T_0, T_1, T_2, T_3 . By Lemma 5.25, we have $T_3 = L$ after suitable reordering. As v is in the outline of T , we have $F \notin \{T_0, T_1, T_2\}$. By Lemma 6.3, we must have $T_j = C^{k_j}L$ for some $k_j \geq 0$ for $j \in \{0, 1, 2\}$. Thus T is of the shape given in Figure 4(c). This yields $n = 7(k_0 + k_1 + k_2) + 5$; in particular $n \equiv 5 \pmod{7}$.

Without loss of generality, we may assume that $k_0 \leq k_1 \leq k_2$. By Lemma 6.5 (2), we have

$$k_0 \leq k_1 \leq k_2 \leq k_0 + 1.$$

From Lemma 6.6, we conclude that

$$k_j = \left\lfloor \frac{k_0 + k_1 + k_2 + j}{3} \right\rfloor = \left\lfloor \frac{\frac{n-5}{7} + j}{3} \right\rfloor$$

for $0 \leq j \leq 2$, as required.

Finally we consider the case that T' has order 1. This case has been considered in Lemma 6.1. \square

Proof of Theorem 3.3. Let T be an optimal tree of order n . If $T \notin \mathcal{S}$, then there are two possibilities: T can be CL -free or it can contain a CL as a rooted subtree. Then Propositions 6.12 and 6.17 respectively show that T has the shape given in Theorem 3.3 with the parameters as given by the theorem. For $n \in \{8, 9, 12, 16\}$, the trees in the exceptional set \mathcal{S} still have this shape. For $n \in \{6, 10, 13, 20\}$ or $n < 4$, however, it is not possible for a tree of order n to have the shape shown in Figure 4 (since n is too small). In these cases, the optimal tree has to be an element of the exceptional set \mathcal{S} , which gives us a unique optimal tree for $n \neq 6$ and two optimal trees for $n = 6$. Finally, let us remark that the asymptotic formulæ given in Theorem 1.2 follow easily from the structure of the trees by means of Lemma 6.2. \square

REFERENCES

- [1] R. J. Baxter, I. G. Enting, and S. K. Tsang. Hard-square lattice gas. *J. Statist. Phys.*, 22(4):465–489, 1980.
- [2] D. Bród and Z. Skupień. Trees with extremal numbers of dominating sets. *Australas. J. Combin.*, 35:273–290, 2006.
- [3] D. Bród and Z. Skupień. Recurrence among trees with most numerous efficient dominating sets. *Discrete Math. Theor. Comput. Sci.*, 10(1):43–55, 2008.
- [4] D. M. Cvetković, M. Doob, and H. Sachs. *Spectra of graphs*. Johann Ambrosius Barth, Heidelberg, third edition, 1995.
- [5] J. Górska and Z. Skupień. Trees with maximum number of maximal matchings. *Discrete Math.*, 307(11-12):1367–1377, 2007.
- [6] R. L. Graham, D. E. Knuth, and O. Patashnik. *Concrete mathematics. A foundation for computer science*. Addison-Wesley, second edition, 1994.
- [7] I. Gutman. Graphs with greatest number of matchings. *Publ. Inst. Math. (Beograd) (N.S.)*, 27(41):67–76, 1980.
- [8] I. Gutman. The energy of a graph: old and new results. In *Algebraic combinatorics and applications (Göteborg, 1999)*, pages 196–211. Springer, Berlin, 2001.
- [9] I. Gutman and O. E. Polansky. *Mathematical concepts in organic chemistry*. Springer-Verlag, Berlin, 1986.
- [10] O. J. Heilmann and E. H. Lieb. Theory of monomer-dimer systems. *Comm. Math. Phys.*, 25:190–232, 1972.
- [11] C. Heuberger and S. G. Wagner. The number of maximum matchings in a tree — online resources. <http://www.math.tugraz.at/~cheub/publications/max-card-matching/>.
- [12] H. Hosoya. Topological index as a common tool for quantum chemistry, statistical mechanics, and graph theory. In *Mathematical and computational concepts in chemistry (Dubrovnik, 1985)*, Ellis Horwood Ser. Math. Appl., pages 110–123. Horwood, Chichester, 1986.

- [13] R. Kirk and H. Wang. Largest number of subtrees of trees with a given maximum degree. *SIAM J. Discrete Math.*, 22(3):985–995, 2008.
- [14] D. E. Knuth. Two notes on notation. *Amer. Math. Monthly*, 99(5):403–422, 1992.
- [15] S. B. Lin and C. Lin. Trees and forests with large and small independent indices. *Chinese J. Math.*, 23(3):199–210, 1995.
- [16] L. Lovász and M. D. Plummer. *Matching theory*, volume 121 of *North-Holland Mathematics Studies*. North-Holland Publishing Co., Amsterdam, 1986.
- [17] R. E. Merrifield and H. E. Simmons. *Topological Methods in Chemistry*. Wiley, New York, 1989.
- [18] H. Prodinger and R. F. Tichy. Fibonacci numbers of graphs. *Fibonacci Quart.*, 20(1):16–21, 1982.
- [19] B. E. Sagan. A note on independent sets in trees. *SIAM J. Discrete Math.*, 1(1):105–108, 1988.
- [20] W. A. Stein et al. *Sage Mathematics Software (Version 4.6)*. The Sage Development Team, 2010. <http://www.sagemath.org>.
- [21] L. A. Székely and H. Wang. Binary trees with the largest number of subtrees. *Discrete Appl. Math.*, 155(3):374–385, 2007.
- [22] S. Wagner and I. Gutman. Maxima and minima of the Hosoya index and the Merrifield-Simmons index: A survey of results and techniques. *Acta Appl. Math.*, 112(3):323–346, 2010.
- [23] H. S. Wilf. The number of maximal independent sets in a tree. *SIAM J. Algebraic Discrete Methods*, 7(1):125–130, 1986.

APPENDIX: TABLES OF REPLACEMENTS

	T	$n := T $	$m(T)$	$m(T_n^*)$
(R1)	$\mathcal{B}(L, L, L, L, \mathcal{AB}(L, L, L))$	10	19	21
	$\mathcal{B}(L, L, L, L, A_6^*)$	11	24	30
(R2)	$\mathcal{B}(A_7^*, F, F, L)$	17	213	216
(R3)	$\mathcal{AB}(L, L, \mathcal{AB}(L, L, \mathcal{AB}(L, L, \mathcal{AB}(L, L, L))))$	17	209	216

TABLE 2. Replacements for trees: $|T| = |T_n^*| = n$ and $m(T) < m(T_n^*)$ hold.

INSTITUT FÜR MATHEMATIK B, TECHNISCHE UNIVERSITÄT GRAZ, AUSTRIA
E-mail address: clemens.heuberger@tugraz.at

DEPARTMENT OF MATHEMATICAL SCIENCES, STELLENBOSCH UNIVERSITY, SOUTH AFRICA
E-mail address: swagner@sun.ac.za

	T	$ T $	$m(T)$	$m_0(T)$	T'	$m(T')$	$m_0(T')$	α
(R4)	$\mathcal{B}A_3^*$	4	1	2	$\mathcal{B}(L, L, L)$	3	1	$\alpha < 2$
	$\mathcal{B}(L, A_3^*)$	5	3	2	$\mathcal{B}(L, L, L, L)$	4	1	$\alpha < 1$
	$\mathcal{B}(A_3^*, A_3^*)$	7	4	4	$\mathcal{B}(L, C_L L)$	7	4	$\alpha \geq 0$
	$\mathcal{B}(A_3^*, A_3^*, A_3^*)$	10	12	8	$\mathcal{B}(L, F, F)$	21	9	$\alpha \geq 0$
(R5)	$\mathcal{AB}(F, F, A_{24}^*)$	34	59049	39366	$C_{C_L}^2 C_L^2 F$	58999	41839	$\alpha > \frac{50}{2473}$
	$\mathcal{AB}(F, A_{14}^*, A_{14}^*)$	34	59049	39366	$C_{C_L}^2 C_L^2 F$	58999	41839	$\alpha > \frac{50}{2473}$
	$\mathcal{AB}(F, A_{14}^*, A_{24}^*)$	44	1594323	1062882	$C_{C_L}^2 C_L^2 L$	1618650	1139139	$\alpha \geq 0$
	$\mathcal{AB}(F, A_{24}^*, A_{24}^*)$	54	43046721	28697814	$C^2 \mathcal{AB}(L, C^2 L, C^3 L)$	44259488	31126973	$\alpha \geq 0$
	$\mathcal{AB}(A_{14}^*, A_{14}^*, A_{14}^*)$	44	1594323	1062882	$C_{C_L}^2 C_L^2 L$	1618650	1139139	$\alpha \geq 0$
	$\mathcal{AB}(A_{14}^*, A_{14}^*, A_{24}^*)$	54	43046721	28697814	$C^2 \mathcal{AB}(L, C^2 L, C^3 L)$	44259488	31126973	$\alpha \geq 0$
	$\mathcal{AB}(A_{14}^*, A_{24}^*, A_{24}^*)$	64	1162261467	774840978	$C^9 L$	1209774005	850782533	$\alpha \geq 0$
	$\mathcal{AB}(A_{24}^*, A_{24}^*, A_{24}^*)$	74	31381059609	20920706406	$C^{10} F$	33062296902	23251305273	$\alpha \geq 0$
(R6)	$\mathcal{B}(L, A_{10}^*)$	12	34	21	$\mathcal{B}(L, L, C_L^2 L)$	41	15	$\alpha < \frac{7}{6}$
(R7)	$\mathcal{B}(L, A_{14}^*)$	16	135	81	$\mathcal{B}(L, L, C_L^3 L)$	153	56	$\alpha < \frac{18}{25}$
	$\mathcal{B}(L, A_{24}^*)$	26	3645	2187	$\mathcal{B}(L, L, C_L C_L C_L)$	4235	1551	$\alpha < \frac{295}{318}$
	$\mathcal{B}(A_{10}^*, A_7^*, A_7^*)$	25	2512	1344	$\mathcal{B}(L, C_L C_L C_L)$	2684	1551	$\alpha \geq 0$
(R8)	$\mathcal{B}(A_{10}^*, A_{10}^*, A_7^*)$	28	6573	3528	$\mathcal{B}(F, C_L, C^2 L)$	7759	3696	$\alpha \geq 0$
	$\mathcal{B}(A_{10}^*, A_{10}^*, A_{10}^*)$	31	17199	9261	$\mathcal{B}(F, C_L, C^2 F)$	20967	9999	$\alpha \geq 0$
	$\mathcal{B}(A_7^*, F, F)$	16	141	72	$\mathcal{B}(L, L, C_L^3 L)$	153	56	$\alpha < \frac{3}{4}$
(R9)	$\mathcal{B}(A_7^*, A_7^*, F)$	19	368	192	$\mathcal{B}(L, L, C_L^3 F)$	418	153	$\alpha < \frac{50}{39}$
	$\mathcal{B}(A_7^*, A_7^*, A_7^*)$	22	960	512	$\mathcal{B}(L, C_L^4 F)$	989	571	$\alpha \geq 0$
	$\mathcal{B}(L, L, L, C_L L)$	9	15	4	$\mathcal{B}(L, A_7^*)$	13	8	$\alpha > \frac{1}{2}$
(R10)	$\mathcal{B}(L, L, C_L^4 L)$	20	571	209	$\mathcal{B}(L, F, A_{14}^*)$	567	243	$\alpha > \frac{2}{17}$
(R11)	$\mathcal{B}(L, F, C A_{14}^*)$	27	5751	2430	$\mathcal{B}(L, F, \mathcal{AB}(F, F, C F))$	5742	2457	$\alpha > \frac{1}{3}$
	$\mathcal{B}(L, F, C A_{24}^*)$	37	155277	65610	$\mathcal{B}(L, F, \mathcal{AB}(F, F, \mathcal{AB}(F, F, C F)))$	155007	66420	$\alpha > \frac{1}{3}$

TABLE 3. Replacements for rooted subtrees: $|T'| = |T|$, $\text{type}(T') = \text{type}(T)$ and $m(T') + \alpha m_0(T') > m(T) + \alpha m_0(T)$ hold for the given range of α . Here, the additional abbreviation $C_L^k S = \mathcal{AB}(L, L, C_L^{k-1} S)$ and $C_{C_L}^k S = \mathcal{AB}(L, C_L, C_L^{k-1} S)$ for $k \geq 1$ have been used, where, as usual, $C_L^0 S = S$ and $C_{C_L}^0 S = S$.